



03801-0379

# LEVEL 4

1 2 3 4 5



## TORNADO GR.1

Beiliegenden Sicherheitstext beachten / Please note the enclosed safety advice

- Ⓢ Beiliegenden Sicherheitstext beachten und nachschlagbereit halten.
- Ⓢ Please note the enclosed safety advice and keep safe for later reference.
- Ⓢ Respecter les consignes de sécurité ci-jointes et les conserver à portée de main.
- Ⓢ Houdt u aan de bijgaande veiligheidsinstructies en hou deze steeds bij de hand.
- Ⓢ Seguire le avvertenze di sicurezza allegate e tenerle a portata di mano.
- Ⓢ Observar y siempre tener a disposición este texto de seguridad adjunto.
- Ⓢ Ter em atenção o texto de segurança anexo e guardá-lo para consulta.

- Ⓢ Overhold vedlagte sikkerhedsanvisninger og hav dem liggende i nærheden.
- Ⓢ Ha alltid vedlagt sikkerhetstekst klar til bruk.
- Ⓢ Beakta bifogad säkerhetstext och håll den i beredskap.
- Ⓢ Huomioi ja säilytä oheiset varoitukset.
- Ⓢ Соблюдать технику безопасности, сохранить инструкцию для дальнейших обращений.
- Ⓢ Przestrzegać załączonego tekstu dotyczącego bezpieczeństwa i mieć go zawsze pod ręką.
- Ⓢ Dodržujte tento příložený bezpečnostní text a mějte ho po ruce.
- Ⓢ A mellékelt biztonossági szöveget vegye figyelembe és tartsa fellapozásra készen.

- Ⓢ Respektujte priložený bezpečnostný text a uchovajte ho pre budúce použitie.
- Ⓢ Respectați textul de siguranță atașat și păstrați-l la îndemână.
- Ⓢ Спазвайте приложения текст за безопасност и го дръжте под ръка за справки.
- Ⓢ Prilolena varnostna navodila izvajajte in jih hranite na vsem dostopnem mestu.
- Ⓢ Λάβετε υπόψη σας το συννημένο κείμενο ασφαλείας και φυλάξτε το ώστε να ανατρέχετε σε αυτό όποτε χρειάζεται.
- Ⓢ Ektekigüvenlik talimatlarını dikkate alıp, bakabileceğiniz bir şekilde muafaza ediniz.

© 2024 Carrera Revell Europe GmbH, Henschelstr. 20-30, D-32257 Bünde.

REVELL IS THE REGISTERED TRADEMARK OF CARRERA REVELL EUROPE GMBH, GERMANY. [www.revell.de](http://www.revell.de)



FR

Papier

BAC  
DE  
TRI



- ☒ Spitzte eines Schraubenziehers erhitzen und auf das herausragende Ende des Plastikstiftes drücken.
- ☒ Heat tip of screwdriver and press on protruding end of plastic pin.
- ☒ Chauffer la pointe du tournevis et appuyer sur la partie saillante de l'extrémité en plastique.
- ☒ De punt van een schroevendraaier verhitten en op het uitstekende einde van de plastic stift drukken.
- ☒ Riscaldare la punta di un cacciavite e premere sull'estremità sporgente del perno di plastica.
- ☒ Calentar la punta del destornillador y presionar el extremo saliente de la clavija de plástico.
- ☒ Aquecer a ponta de uma chave de parafusos e pressionar sobre a extremidade protuberante do pino plástico.
- ☒ Opvarm spidsen af en skruetrækker og tryk på den udragende ende af plastikstiften.
- ☒ Varm opp spissen på en skruetrekker og trykk på den utstikkende enden av plaststiften.
- ☒ Värm toppen av en skruvmejsel och tryck den på plaststiftens utstickande ände.
- ☒ Kuumenna ruuvimeisselin päättä ja paina esiintyntyvän muovipuikon päätä.
- ☒ Нагреть наконечник отвертки и надавить на выступающий конец пластмассового штифта.
- ☒ Ogrzać czubek śrubokrętu i przycisnąć do końcówki wystającego plastikowego kolka.
- ☒ Nahřejte špičku šroubováku a přitiskněte ji na vyčnívající konec plastového kolka.
- ☒ Melegítse meg a csavarhúzó hegyét és nyomja rá a műanyag csap kiálló végére.
- ☒ Zohrejte hrot škrutkovača a zatlačte na vyčnívající konec plastového kolka.
- ☒ Incălzii vârful unei șurubelnițe și apăsăți pe capătul proeminent al știftului de plastic.
- ☒ Нагрейте верх на отвертку и натисните подающая ее край на пластмассовый штифт.
- ☒ Konicno izvijáča segrejte in pritisnite na izstopajoči konec plastičnega zatiča.
- ☒ Θερμάνετε τη μύτη ενός κατσαβιδιού και πιέστε στο άκρο του πλαστικού πείρου που προεξέχει.
- ☒ Tornavidanın ucunu ısıtin ve plastik pimini çikinti yapın ucuna tutun.



- ☒ Abziehbild in Wasser einweichen und anbringen.
- ☒ Soak and apply decals.
- ☒ Mouiller et appliquer les décalcomanies.
- ☒ Transfer in water even laten weken en aanbrengen.
- ☒ Immergere la decalcomania nell'acqua e applicarla.
- ☒ Mojar y aplicar calcomanías.
- ☒ Amolecer o decalque em água e aplicar.
- ☒ Gör överföringsbilledet vådt og sæt det på.
- ☒ Myk opp avtrekkingsbildet i vann og sett på.
- ☒ Blötlägg dekalen i vatten och sätt på den.
- ☒ Pehmitä siirtokuva vedessä ja siirrä paikalleen.
- ☒ Опустите переводную картинку в воду и нанесите.
- ☒ Namoczyc kalkomanie w wodzie i przykleić.
- ☒ Nechte obtisk odmočit ve vodě a přilepte.
- ☒ Merítse vízbe és helyezze fel a matricát.
- ☒ Obtláčkový obrázok namočte do vody a priložte na.
- ☒ Inmuiati abțibildul în apă și aplicați-l.
- ☒ Потопите ваденката във вода и я поставете.
- ☒ Prelepnicu namakajte v vodi. In namestite.
- ☒ Μουσκεύετε σε νερό και τοποθετείτε τις χαλκομανιές.
- ☒ Çikartmayı suda yumuşatın ve takın.



\*

- ☒ Zur Anbringung der Abziehbilder empfohlen.
- ☒ Recommended for affixing the decals.
- ☒ Recommandé pour l'application des décalcomanies.
- ☒ Aanbevolen voor het aanbrengen van de transfers.
- ☒ Raccomandato per l'applicazione delle decalcomanie.
- ☒ Recomendado para fijar bien las calcomanías.
- ☒ Recomendado para a fixação dos autocolantes.
- ☒ Anbefales til anbringelse af overføringsbillederne.
- ☒ Anbefales til å feste avtrekksbilder.
- ☒ Rekommenderad för montering av klisterdekalerna.
- ☒ Suositellaan siirtokuvien siirtämiseen.
- ☒ Рекомендуется для нанесения переводных картинок.
- ☒ Doporučujeme k umístění obtiskovacích obrázků.
- ☒ A matrica felhelyezéséhez ajánlható.
- ☒ Odporúča sa pre umiestnenie obtláčkového obrázku.
- ☒ Recomandat pentru aplicarea pieselor transparente.
- ☒ Препоръчва се за поставяне на ваденки.
- ☒ Pri nameščenju nalepnice priporočamo.
- ☒ Συνιστάται για την τοποθέτηση των χαλκομανιών.
- ☒ Çikartmaların takılması için önerilir.



\*

- ☒ Zur Anbringung der Klarteile empfohlen.
- ☒ Recommended to fix clear parts.
- ☒ Recommandé pour fixer les pièces transparentes.
- ☒ Aanbevolen voor het aanbrengen van transparante delen.
- ☒ Raccomandato per l'applicazione delle parti trasparenti.
- ☒ Recomendado para fijar las piezas transparentes.
- ☒ Recomendado para a aplicação das peças transparentes.
- ☒ Anbefales til anbringelse af de klare dele.
- ☒ Anbefales til å feste klare deler.
- ☒ Rekommenderad för montering av de genomskinliga detaljerna.
- ☒ Suositellaan läpinäkyvien osien siirtämiseen.
- ☒ Рекомендуется для крепления прозрачных деталей.
- ☒ Zalecane do przyklejenia przezroczystych części.
- ☒ Doporučujeme k umístění průhledných dílů.
- ☒ Az átlátszó darabok felhelyezéséhez ajánlható.
- ☒ Odporúča sa pre umiestnenie čírych dielov.
- ☒ Recomandat pentru aplicarea pieselor transparente.
- ☒ Препоръчва се за поставяне на прозрачни части.
- ☒ Pri nameščenju prozornih delov priporočamo.
- ☒ Συνιστάται για την τοποθέτηση των διάφανων μερών.
- ☒ Şeffaf parçaların takılması için önerilir.

\*

- ☒ Nicht enthalten
- ☒ Not included
- ☒ Non fourni
- ☒ Behoort niet tot de levering
- ☒ Non incluso
- ☒ No incluido
- ☒ Não incluído
- ☒ Medfølger ikke
- ☒ Ikke inkludert
- ☒ Ingår ej
- ☒ Ei sisällä
- ☒ Не съдържа
- ☒ Nie wchodzi w zakres dostawy
- ☒ Není obsaženo
- ☒ Nem tartalmazza
- ☒ Neobsahuje
- ☒ Nu este inclus
- ☒ Не се включва в комп.
- ☒ Ni priloženo
- ☒ Δεν περιλαμβάνεται
- ☒ İçermiyor

# Benötigte Farben / Required colours

- FR Peintures nécessaires
- NL Benodigde kleuren
- IT Colori necessari
- ES Colores necesarios
- PT Cores necessárias
- DK Nodvendige farver
- NO Nodvendige farger
- SE Erforderliga farger
- FI Tarvittavat värit
- RU Необходимые краски
- PL Potrzebne kolory
- CZ Potřebné barvy
- HU Szükséges színek
- SK Požadované farby
- RO Culoari necesare
- BG Необходими цветове
- SI Potrebne barve
- GR Απαιτούμενα χρώματα
- TR Gerekli renkler

65

**A**

- DE Bronze grün matt
- GB Bronze green matt
- FR Vert bronze mat
- NL Bronsgroen mat
- IT Verde bronzo opaco
- ES Verde bronce mate
- PT Verde bronze mate
- DK Bronze grøn mat
- NO Bronsegrønn matt
- SE Bronsgrön matt
- FI Pronssinvihreä matta
- RU Бронзово-зелёный матовый
- PL Brązowozielony matowy
- CZ Bronzová zelená matný
- HU Bronz zöld, fénytelen
- SK Bronzovo zelená matný
- RO Verde-bronz mat
- BG Бронзовозелено матово
- SI Bronasto-zelena mat
- GR Λαδί ματ
- TR Bakır yeşili mat

79

**B**

- DE Blaugrau matt
- GB Blue-grey matt
- FR Gris bleu mat
- NL Blauwgrijs mat
- IT Grigio bluastro opaco
- ES Azul grisáceo mate
- PT Azul acinzentado mate
- DK Blågrøn mat
- NO Gråblå matt
- SE Blågrön matt
- FI Harmaansininen matta
- RU Серо-синий матовый
- PL Niebieskoszary matowy
- CZ Sedomodrá matný
- HU Kékesszürke, fénytelen
- SK Sivomodrá matný
- RO Albastru cenuşiu mat
- BG Синьо-сиво матово
- SI Modro-siva mat
- GR Γκρι-μπλε ματ
- TR Gri mavi mat

47

**C**

- DE Mausgrau matt
- GB Mouse grey matt
- FR Gris souris mat
- NL Muisgrijs mat
- IT Grigio topo opaco
- ES Gris claro mate
- PT Cinzento claro mate
- DK Musegrå mat
- NO Musegrå matt
- SE Musgrå matt
- FI Hiienharmaa matta
- RU Мышино-серый матовый
- PL Szary myszy matowy
- CZ Mýší šedá matný
- HU Egérszürke, fénytelen
- SK Mýšacia sivá matný
- RO Gri-soarece mat
- BG Мишосиво матово
- SI Mišje-siva mat
- GR Γκρι ποτικί ματ
- TR Kirli gri mat

731

**E**

- DE Rot klar
- GB Red clear
- FR Rouge clair
- NL Rood helder
- IT Rosso chiaro
- ES Rojo claro
- PT Vermelho transparente
- DK Rødbrun klar
- NO Rod klar
- SE Rødbrun klar
- FI Punainen kirkas
- RU Красный прозрачный
- PL Czerwony przezroczysty
- CZ Červená bezbarvá
- HU Piros, világos
- SK Červená číry
- RO Roşu curat
- BG Червено бистро
- SI Rdeča čista
- GR Κόκκινο διάφανο
- TR Kırmızı canlı

60%

57

**F**

05

40%

- |                      |   |                     |
|----------------------|---|---------------------|
| DE Grau matt         | + | DE Weiß matt        |
| GB Grey matt         |   | GB White matt       |
| FR Gris mat          |   | FR Blanc mat        |
| NL Grijs mat         |   | NL Wit mat          |
| IT Grigio opaco      |   | IT Bianco opaco     |
| ES Gris mate         |   | ES Blanco mate      |
| PT Cinzento mate     |   | PT Branco mate      |
| DK Grå mat           |   | DK Hvid mat         |
| NO Grå matt          |   | NO Hvit matt        |
| SE Grå matt          |   | SE Vit matt         |
| FI Harmaa matta      |   | FI Valkoinen matta  |
| RU Серый матовый     |   | RU Белый матовый    |
| PL Szary matowy      |   | PL Biały matowy     |
| CZ Šedá matný        |   | CZ Bílá matný       |
| HU Szürke, fénytelen |   | HU Fehér, fénytelen |
| SK Sivá matný        |   | SK Biela matný      |
| NO Gri mat           |   | NO Alb mat          |
| BG Сиво матово       |   | BG Бяло матово      |
| SI Siva mat          |   | SI Bela mat         |
| GR Γκρι ματ          |   | GR Ασπρο ματ        |
| TR Gri mat           |   | TR Beyaz mat        |

302

**G**

- DE Schwarz seidenmatt
- GB Black silk matt
- FR Noir satiné mat
- NL Zwart zijdemat
- IT Nero opaco satinato
- ES Negro mate satinado
- PT Preto mate sedoso
- DK Sort silkematt
- NO Sort silkematt
- SE Svart sidenmatt
- FI Musta silkimatta
- RU Чёрный шелковисто-матовый
- PL Czarny jedwabście matowy
- CZ Černá jemně matný
- HU Fekete, fakóselymes
- SK Čierna hodvábne matný
- NO Negru satinat
- BG Черно коприненоматово
- SI Črna svileno-mat
- GR Μαύρο σατινέ
- TR Siyah ipeksi mat

09

**H**

- DE Anthrazit matt
- GB Anthracite matt
- FR Anthracite mat
- NL Antraciet mat
- IT Antracite opaco
- ES Antracita mate
- PT Antracite mate
- DK Antracitgrå mat
- NO Antrasitt matt
- SE Antracitgrå matt
- FI Antrasiinharmaa matta
- RU Антрацит матовый
- PL Antracyt matowy
- CZ Antracitová šedá matný
- HU Antracit, fénytelen
- SK Čierna uhľová matný
- NO Antracit mat
- BG Антрацит матово
- SI Antracit mat
- GR Γκρι ανθρακί ματ
- TR Antrazit mat

05

**I**

- DE Weiß matt
- GB White matt
- FR Blanc mat
- NL Wit mat
- IT Bianco opaco
- ES Blanco mate
- PT Branco mate
- DK Hvid mat
- NO Hvit matt
- SE Vit matt
- FI Valkoinen matta
- RU Белый матовый
- PL Biały matowy
- CZ Bílá matný
- HU Fehér, fénytelen
- SK Biela matný
- NO Alb mat
- BG Бяло матово
- SI Bela mat
- GR Ασπρο ματ
- TR Beyaz mat

89

**J**

- DE Beige matt
- GB Beige matt
- FR Beige mat
- NL Beige mat
- IT Beige opaco
- ES Beige mate
- PT Beige mate
- DK Beige mat
- NO Beige matt
- SE Beige matt
- FI Beige matta
- RU Бежевый матовый
- PL Beżowy matowy
- CZ Běžová matný
- HU Bézs, fénytelen
- SK Běžová matný
- NO Bej mat
- BG Бежово матово
- SI Bež mat
- GR Μπεζ ματ
- TR Bej mat

91

**K**

- DE Eisen metallic
- GB Iron metallic
- FR Fer métallique
- NL IJzer metallic
- IT Ferro metallico
- ES Acero metálico
- PT Aço metálico
- DK Stål metallisk
- NO Jern metallic
- SE Stål metallic
- FI Teräs metallinen
- RU Сталь металл
- PL Grafit metaliczny
- CZ Ocelová metalizovný
- HU Acélmetál
- SK Ocelová metaliza
- NO Fier metalic
- BG Желязо металик
- SI Železna kovinska
- GR Χρώμα σιδήρου μεταλλικό
- TR Metalik metalik

60%

91

**M**

87

40%

- |   |   |                         |
|---|---|-------------------------|
| DE Eisen metallic                                       | + | DE Erdfarbe matt        |
| GB Iron metallic  |   | GB Earth matt           |
| FR Fer métallique                                       |   | FR Couleur terre mat    |
| NL IJzer metallic                                       |   | NL Aardkleur mat        |
| IT Ferro metallico                                      |   | IT Color terra opaco    |
| ES Acero metálico                                       |   | ES Marrón tierra mate   |
| PT Aço metálico   |   | PT Castanho terra mate  |
| DK Stål metallisk                                       |   | DK Jordfarve mat        |
| NO Jern metallic  |   | NO Jordbrun matt        |
| SE Stål metallic  |   | SE Jordfärg matt        |
| FI Teräs metallinen                                     |   | FI Maanruskea matta     |
| RU Сталь металл <td></td> <td>RU Земельный матовый</td> |   | RU Земельный матовый    |
| PL Grafit metaliczny                                    |   | PL Ziemiasty matowy     |
| CZ Ocelová metalizovný                                  |   | CZ Zemité hnědá matný   |
| HU Acélmetál  |   | HU Földszínű, fénytelen |
| SK Ocelová metaliza                                     |   | SK Zemito hnědá matný   |
| NO Fier metalic   |   | NO Maro pământiu mat    |
| BG Желязо металик                                       |   | BG Земнокафяво матово   |
| SI Železna kovinska                                     |   | SI Zemeljska-barva mat  |
| GR Χρώμα σιδήρου μεταλλικό                              |   | GR Καφέ γήινο ματ       |
| TR Metalik metalik                                      |   | TR Toprak kahvesi mat   |

50% 15 **N** 05 50%

<ul style="list-style-type: none"> <li>DE Gelb matt</li> <li>GB Yellow matt</li> <li>FR Jaune mat</li> <li>NL Geel mat</li> <li>IT Giallo opaco</li> <li>ES Amarillo mate</li> <li>PT Amarelo mate</li> <li>DK Gul mat</li> <li>NO Gul matt</li> <li>SE Gul matt</li> <li>F Keltainen matta</li> <li>RU Жёлтый матовый</li> <li>PL Żółty matowy</li> <li>CZ Žlutá matný</li> <li>HU Sárga, fénytelen</li> <li>SK Žltá matný</li> <li>NO Galben mat</li> <li>BG Жълто матово</li> <li>S Rumena mat</li> <li>GR Κίτρινο ματ</li> <li>TR Sarı mat</li> </ul>	+	<ul style="list-style-type: none"> <li>DE Weiß matt</li> <li>GB White matt</li> <li>FR Blanc mat</li> <li>NL Wit mat</li> <li>IT Bianco opaco</li> <li>ES Blanco mate</li> <li>PT Branco mate</li> <li>DK Hvid mat</li> <li>NO Hvit matt</li> <li>SE Vit matt</li> <li>F Valkoinen matta</li> <li>RU Белый матовый</li> <li>PL Biały matowy</li> <li>CZ Bílá matný</li> <li>HU Fehér, fénytelen</li> <li>SK Biela matný</li> <li>NO Alb mat</li> <li>BG Бяло матово</li> <li>S Bela mat</li> <li>GR Λευρό ματ</li> <li>TR Beyaz mat</li> </ul>
---	---	--

31 **O**

- DE Feuerrot glänzend
- GB Fiery red gloss
- FR Rouge feu brillant
- NL Vuurood glanzend
- IT Rosso fuoco lucido
- ES Rojo fuego brillante
- PT Vermelho vivo brilhante
- DK Flammerød blank
- NO Ildrød glansende
- SE Eldröd blank
- F Tulenpunainen kiiltävä
- RU Огненно-красный глянец
- PL Ognistoczerwony błyszczący
- CZ Ohnivě červená lesklý
- HU Tűzpiros, fényes
- SK Ohnivá červená lesklý
- NO Rosu aprins strålucitor
- BG Огненочервено гланцово
- S Ognjeno-rdeča sijoca
- GR Κόκκινο φωτιστάς γυαλιστερό
- TR Alev kırmızısı parlak

51 **P**

- DE Ultramarinblau glänzend
- GB Ultramarine blue gloss
- FR Bleu outremer brillant
- NL Ultramarineblauw glanzend
- IT Blu oltremare lucido
- ES Azul marino brillante
- PT Ultra marinho brilhante
- DK Ultra marineblå blank
- NO Ultra marineblå glansende
- SE Ultramarinblå blank
- F Ultramarini kiiltävä
- RU Ультрамарин глянец
- PL Ultramaryna błyszcząca
- CZ Ultramarinová modř lesklý
- HU Ultramarin kék, fényes
- SK Ultramarin modrá lesklý
- NO Albastru ultramarin strålucitor
- BG Ултрамарин гланцово
- S Ultramarinska-modra sijoca
- GR Μπλε βαθυ γυαλιστερό
- TR Lacivert parlak

90 **Q**

- DE Silber metallic
- GB Silver metallic
- FR Argent métallique
- NL Zilver metallic
- IT Argento metallico
- ES Plata metálico
- PT Prata metálico
- DK Sølv metallisk
- NO Sølv metallic
- SE Silver metallic
- F Hopea metallinen
- RU Серебрянный металл
- PL Srebrny metaliczny
- CZ Stříbrná metalizový
- HU Ezüstmetál
- SK Strieborná metaliza
- NO Argintiu metallic
- BG Сребро металик
- S Srebrna kovinska
- GR Ασημί μεταλλικό
- TR Gümüş rengi metalik

48 **S**

- DE Seegrün matt
- GB Sea green matt
- FR Vert mer mat
- NL Zeegroen mat
- IT Verde mare opaco
- ES Verde mar mate
- PT Verde mar mate
- DK Havgrøn mat
- NO Sjøgrønn matt
- SE Havsgrün matt
- F Merenvihreä matta
- RU Морская волна матовый
- PL Morska zieloná matowy
- CZ Mořská zelená matný
- HU Tengerzöld, fénytelen
- SK Morská zelená matný
- NO Verde-marin mat
- BG Морскозелено матово
- S Jezersko-zelena mat
- GR Πράσινο βαθύ ματ
- TR Deniz yeşili mat

70% 05 **T** 57 30%

<ul style="list-style-type: none"> <li>DE Weiß matt</li> <li>GB White matt</li> <li>FR Blanc mat</li> <li>NL Wit mat</li> <li>IT Bianco opaco</li> <li>ES Blanco mate</li> <li>PT Branco mate</li> <li>DK Hvid mat</li> <li>NO Hvit matt</li> <li>SE Vit matt</li> <li>F Valkoinen matta</li> <li>RU Белый матовый</li> <li>PL Biały matowy</li> <li>CZ Bílá matný</li> <li>HU Fehér, fénytelen</li> <li>SK Biela matný</li> <li>NO Alb mat</li> <li>BG Бяло матово</li> <li>S Bela mat</li> <li>GR Λευρό ματ</li> <li>TR Beyaz mat</li> </ul>	+	<ul style="list-style-type: none"> <li>DE Grau matt</li> <li>GB Grey matt</li> <li>FR Gris mat</li> <li>NL Grijs mat</li> <li>IT Grigio opaco</li> <li>ES Gris mate</li> <li>PT Cinzento mate</li> <li>DK Grå mat</li> <li>NO Grå matt</li> <li>SE Grå matt</li> <li>F Harmaa matta</li> <li>RU Серый матовый</li> <li>PL Szary matowy</li> <li>CZ Seda matný</li> <li>HU Szürke, fénytelen</li> <li>SK Sivá matný</li> <li>NO Gri mat</li> <li>BG Сиво матово</li> <li>S Siva mat</li> <li>GR Γκρι ματ</li> <li>TR Gri mat</li> </ul>
--	---	--

46 **U**

- DE Nato-Oliv matt
- GB Nato olive matt
- FR Olive OTAN mat
- NL Navo-olijf mat
- IT Oliva Nato opaco
- ES Oliva Nato mate
- PT Verde Nato mate
- DK Nato oliven mat
- NO Nato oliven matt
- SE Nato olivgrön matt
- F Oliivi, NATO matta
- RU Оливковый НАТО матовый
- PL Oliwka NATO matowy
- CZ Olivová Nato matný
- HU Nato olajsárga, fénytelen
- SK Nato olivová matný
- NO Måsliniu nato mat
- BG Натовскомаслинено матово
- S Nato-olivna mat
- GR Λαδί Nato ματ
- TR Asker yeşili mat

50% 46 **V** 08 50%

<ul style="list-style-type: none"> <li>DE Nato-Oliv matt</li> <li>GB Nato olive matt</li> <li>FR Olive OTAN mat</li> <li>NL Navo-olijf mat</li> <li>IT Oliva Nato opaco</li> <li>ES Oliva Nato mate</li> <li>PT Verde Nato mate</li> <li>DK Nato oliven mat</li> <li>NO Nato oliven matt</li> <li>SE Nato olivgrön matt</li> <li>F Oliivi, NATO matta</li> <li>RU Оливковый НАТО матовый</li> <li>PL Oliwka NATO matowy</li> <li>CZ Olivová Nato matný</li> <li>HU Nato olajsárga, fénytelen</li> <li>SK Nato olivová matný</li> <li>NO Måsliniu nato mat</li> <li>BG Натовскомаслинено матово</li> <li>S Nato-olivna mat</li> <li>GR Λαδί Nato ματ</li> <li>TR Asker yeşili mat</li> </ul>	+	<ul style="list-style-type: none"> <li>DE Schwarz matt</li> <li>GB Black matt</li> <li>FR Noir mat</li> <li>NL Zwart mat</li> <li>IT Nero opaco</li> <li>ES Negro mate</li> <li>PT Preto mate</li> <li>DK Sort mat</li> <li>NO Sort matt</li> <li>SE Svart matt</li> <li>F Musta matta</li> <li>RU Чёрный матовый</li> <li>PL Czarny matowy</li> <li>CZ Černá matný</li> <li>HU Fekete, fénytelen</li> <li>SK Čierna matný</li> <li>NO Negro mat</li> <li>BG Черно матово</li> <li>S Crna mat</li> <li>GR Μαύρο ματ</li> <li>TR Siyah mat</li> </ul>
---	---	--

15 **X**

- DE Gelb matt
- GB Yellow matt
- FR Jaune mat
- NL Geel mat
- IT Giallo opaco
- ES Amarillo mate
- PT Amarelo mate
- DK Gul mat
- NO Gul matt
- SE Gul matt
- F Keltainen matta
- RU Жёлтый матовый
- PL Żółty matowy
- CZ Žlutá matný
- HU Sárga, fénytelen
- SK Žltá matný
- NO Galben mat
- BG Жълто матово
- S Rumena mat
- GR Κίτρινο ματ
- TR Sarı mat



<ul style="list-style-type: none"> <li>DE Beispiel: mischen</li> <li>GB Example: mixing</li> <li>FR Exemple: mélanger</li> <li>NL Voorbeeld: mengen</li> <li>IT Esempio: mescolare</li> <li>ES Ejemplo: mezcla</li> <li>PT Exemplo: misturar</li> <li>DK Eksempel: blanding</li> <li>NO Eksempel: blanda</li> <li>SE Eximerkki:</li> <li>F Esimerkki:</li> </ul>	<ul style="list-style-type: none"> <li>RU Пример: смеси</li> <li>PL Przykład: mieszanie</li> <li>CZ Příklad: míchání</li> <li>HU Példa: keverés</li> <li>SK Příklad: miešanie</li> <li>NO Exempler: amestecare</li> <li>BG Пример: смесва</li> <li>S Primer: mešanje</li> <li>GR Παράδειγμα: ανάμιξη</li> <li>TR Örnek: karıştırma</li> </ul>
--	---

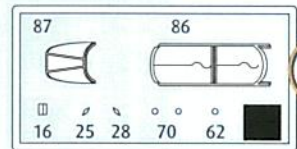
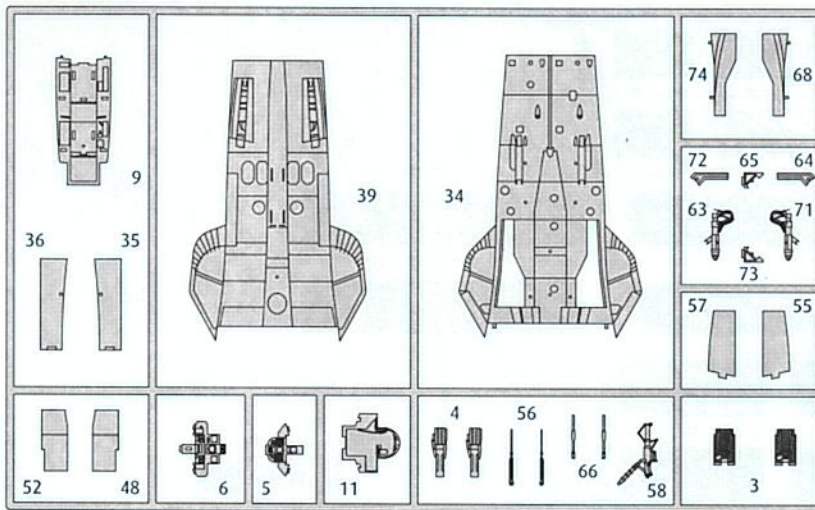

Clear

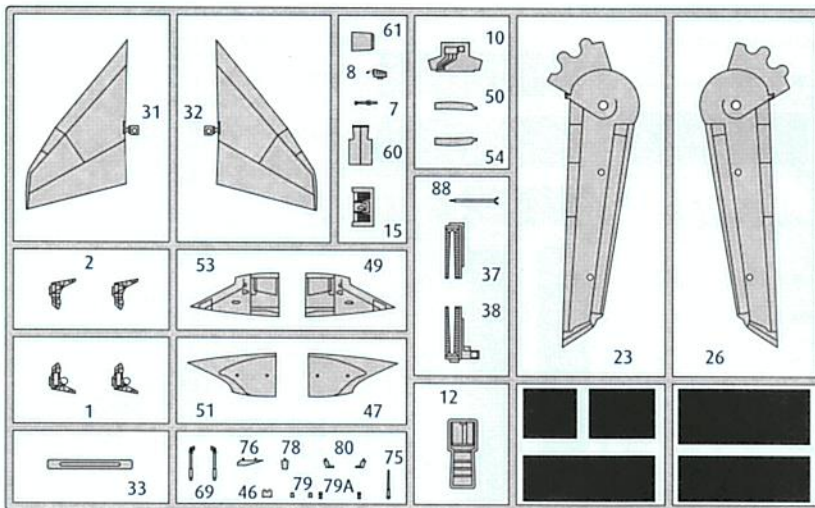

- Ⓢ Nicht benötigte Teile
- Ⓢ Parts not used.
- Ⓢ Pièces non utilisées.
- Ⓢ Niet benodigde onderdelen.
- Ⓢ Parti non necessarie.
- Ⓢ Piezas no utilizadas.
- Ⓢ Peças não utilizadas.
- Ⓢ Dele der ikke skal bruges.
- Ⓢ Deler som ikke er nødvendige.
- Ⓢ Eј nōdvāndiga delar.
- Ⓢ Tarpeettomat osat.
- Ⓢ Неиспользуемые детали.
- Ⓢ Niepotrzebne części.
- Ⓢ Nepotrebné diely.
- Ⓢ Szükségtelen alkatrészek.
- Ⓢ Nepotrebné diely.
- Ⓢ Piese care nu sunt necesare.
- Ⓢ Неужни детали.
- Ⓢ Nepotrebni deli.
- Ⓢ Μη χρησιμοποιούμενα μέρη.
- Ⓢ Gereklі olmayan parçalar.

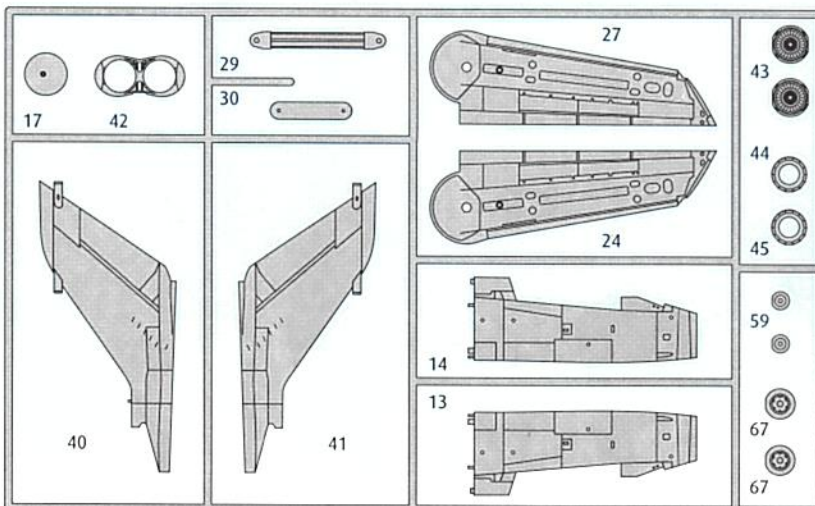

- Ⓢ Kundenservice: [www.revell-service.de](http://www.revell-service.de)
- Ⓢ Customer Service: [www.revell-service.de](http://www.revell-service.de)
- Ⓢ Customer Service: [www.revell-service.de](http://www.revell-service.de)
- Ⓢ Service clientèle: [www.revell-service.de](http://www.revell-service.de)
- Ⓢ Klantenservice: [www.revell-service.de](http://www.revell-service.de)
- Ⓢ Servicio al cliente: [www.revell-service.de](http://www.revell-service.de)
- Ⓢ Servizio clienti: [www.revell-service.de](http://www.revell-service.de)
- Ⓢ Serviço de apoio ao cliente: [www.revell-service.de](http://www.revell-service.de)
- Ⓢ Kundenservice: [www.revell-service.de](http://www.revell-service.de)
- Ⓢ Kundenservice: [www.revell-service.de](http://www.revell-service.de)
- Ⓢ Kundtjänst: [www.revell-service.de](http://www.revell-service.de)

- Ⓢ Asiakaspalvelu: [www.revell-service.de](http://www.revell-service.de)
- Ⓢ Служба поддержки клиентов: [www.revell-service.de](http://www.revell-service.de)
- Ⓢ Dział obsługi klienta: [www.revell-service.de](http://www.revell-service.de)
- Ⓢ Zákaznický servis: [www.revell-service.de](http://www.revell-service.de)
- Ⓢ Ügyfélszolgálat: [www.revell-service.de](http://www.revell-service.de)
- Ⓢ Zákaznický servis: [www.revell-service.de](http://www.revell-service.de)
- Ⓢ Serviciul clienți: [www.revell-service.de](http://www.revell-service.de)
- Ⓢ Отдел за обслужване на клиенти: [www.revell-service.de](http://www.revell-service.de)
- Ⓢ Služba za pomoč strankam: [www.revell-service.de](http://www.revell-service.de)
- Ⓢ Τμήμα εξυπηρέτησης πελατών: [www.revell-service.de](http://www.revell-service.de)
- Ⓢ Müşteri hizmetleri: [www.revell-service.de](http://www.revell-service.de)

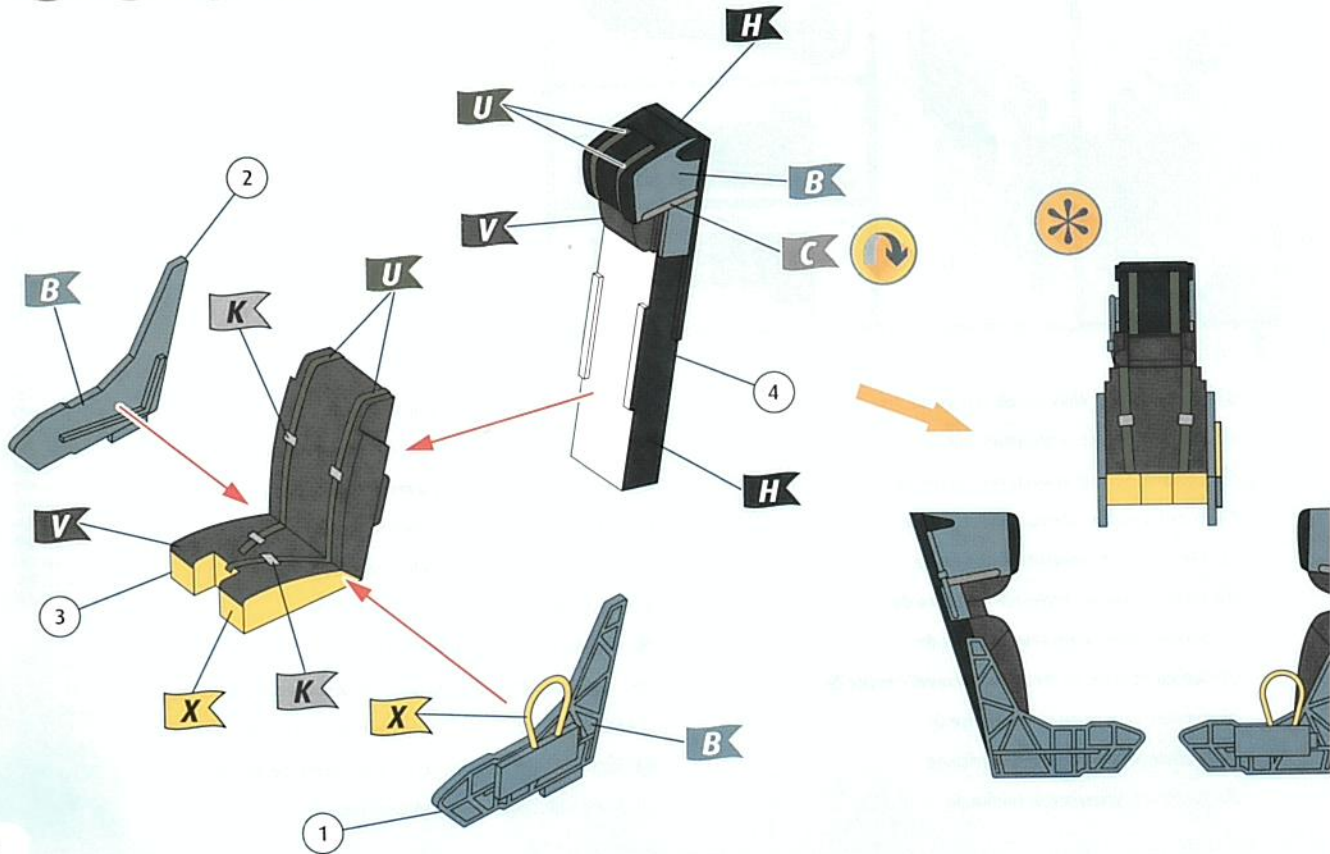
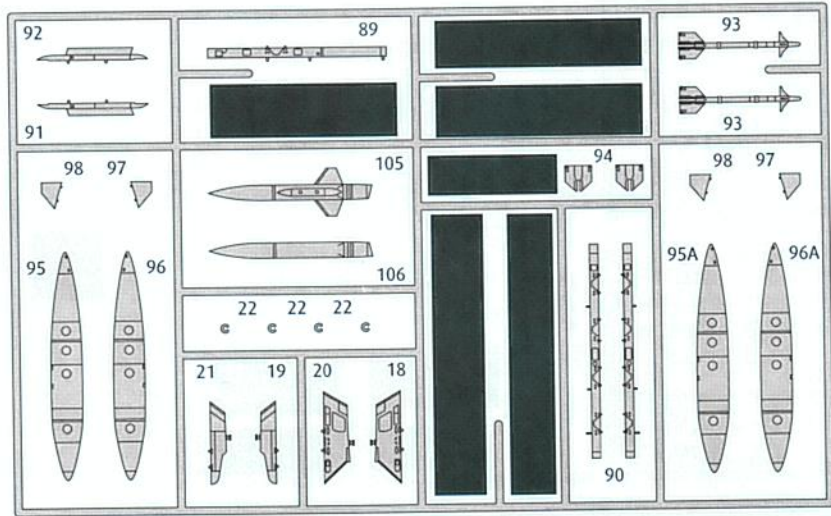
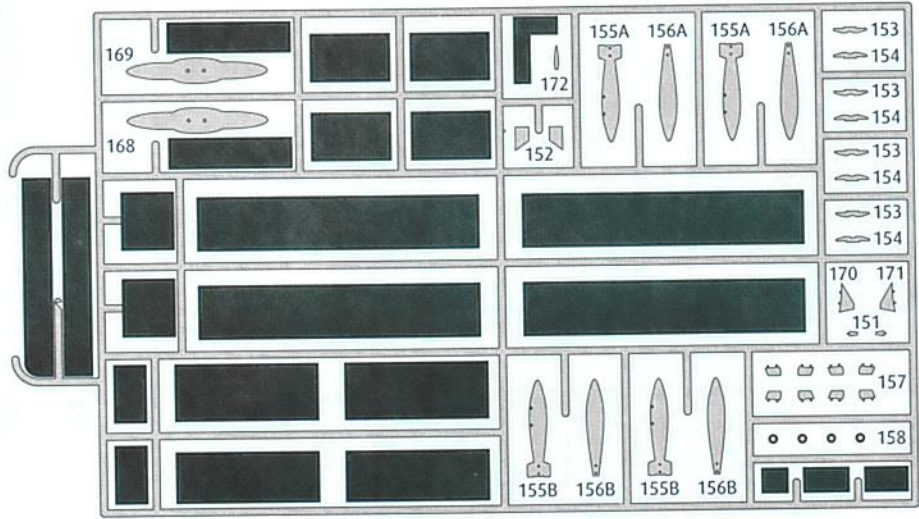

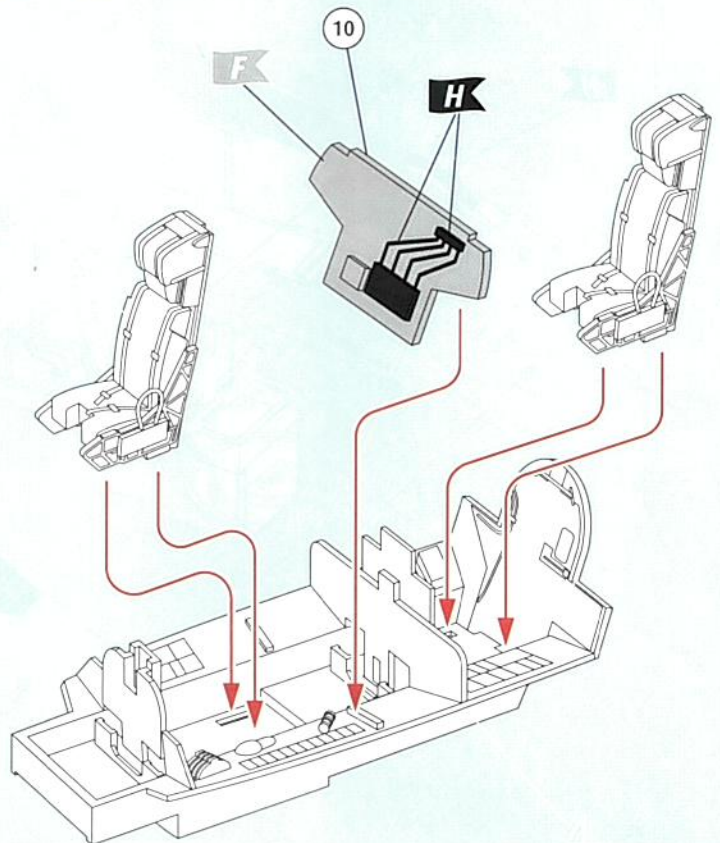
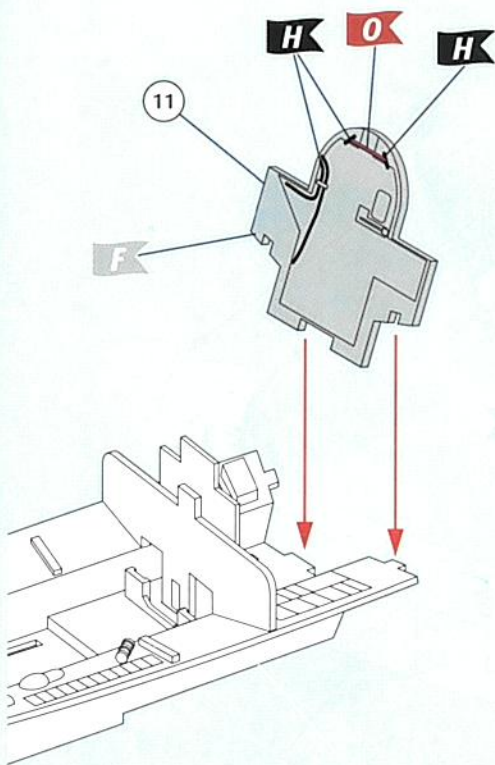
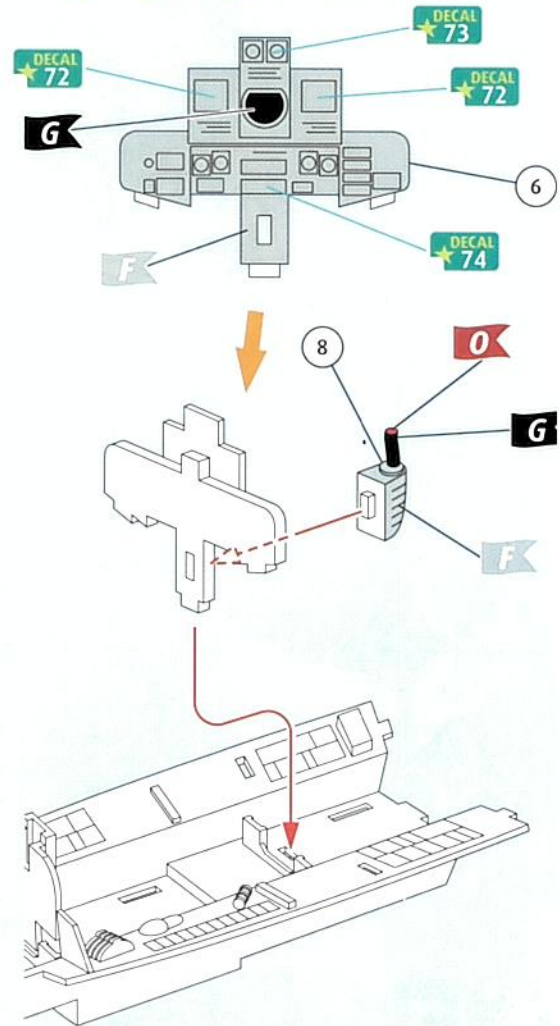
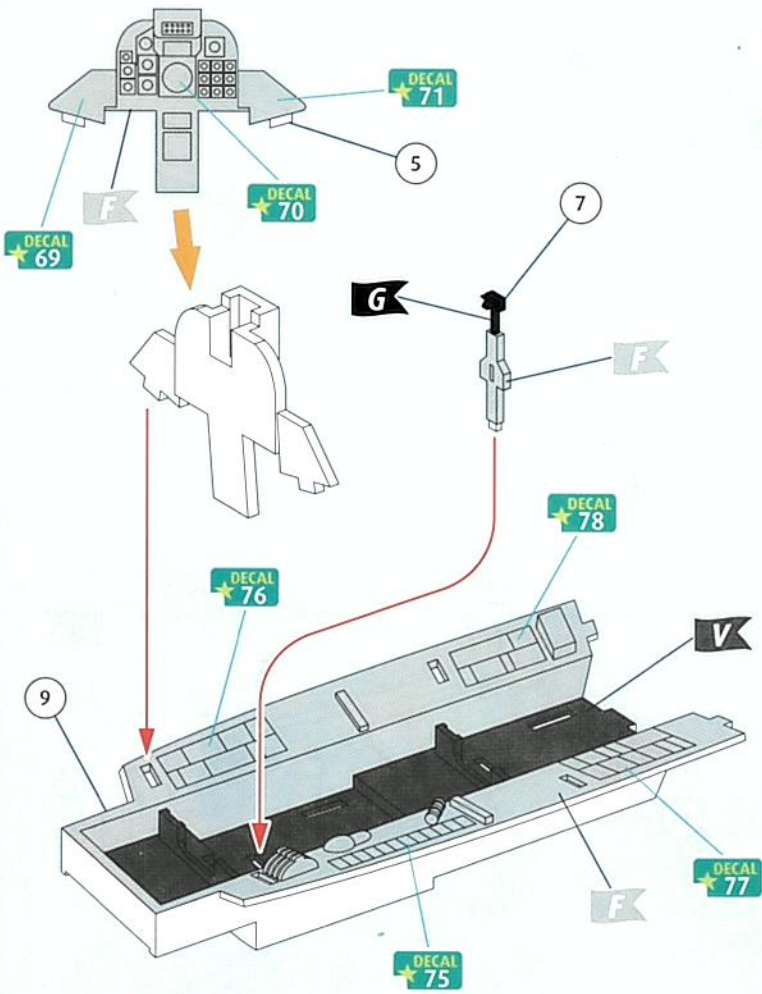

6

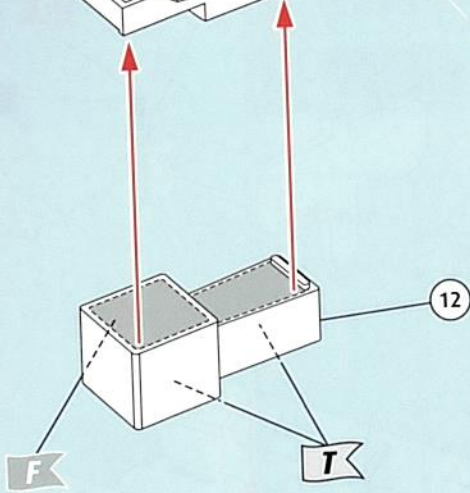
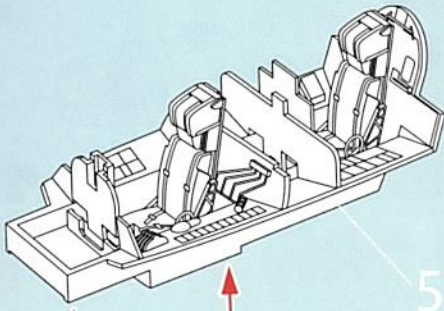

7

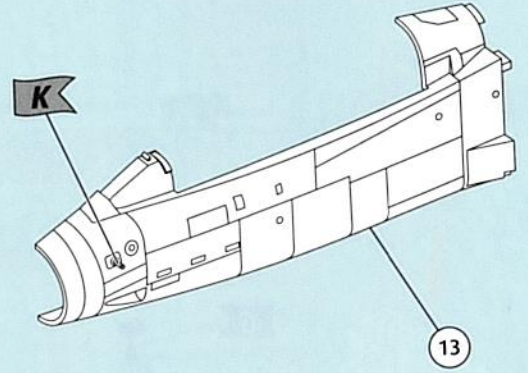

7a

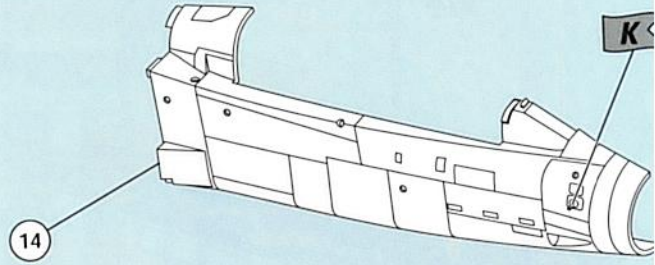

8

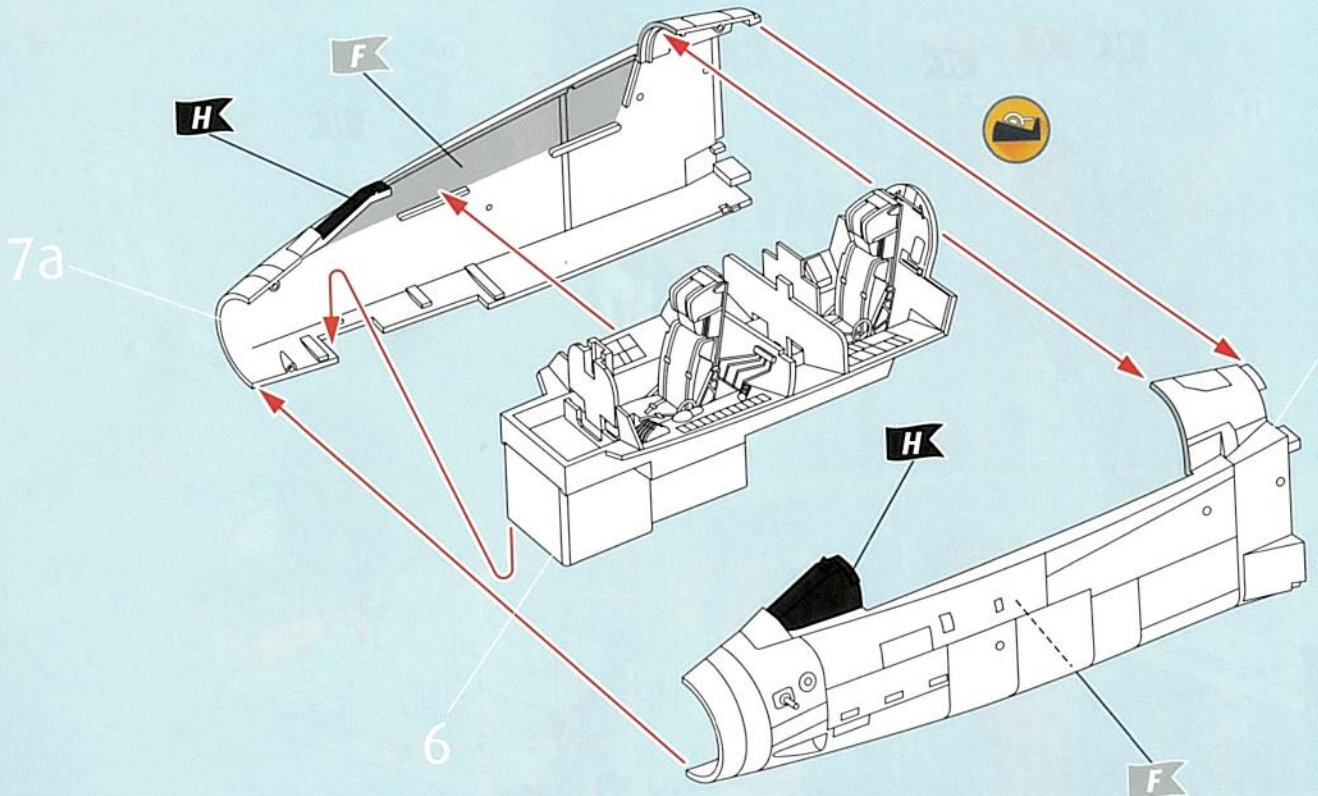

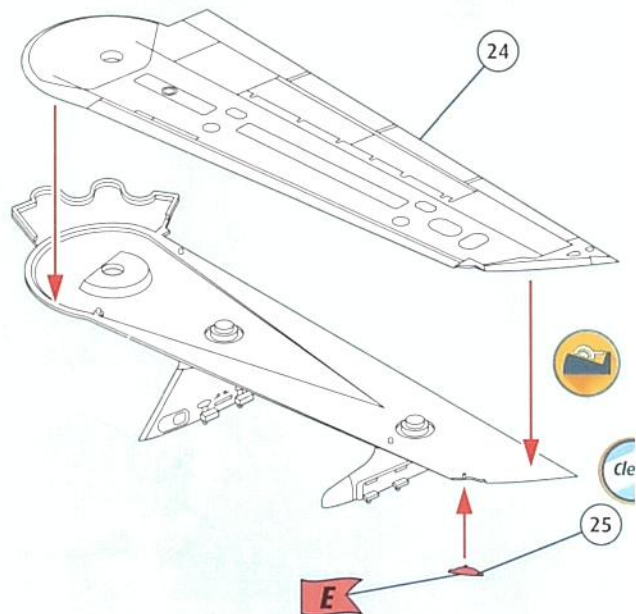
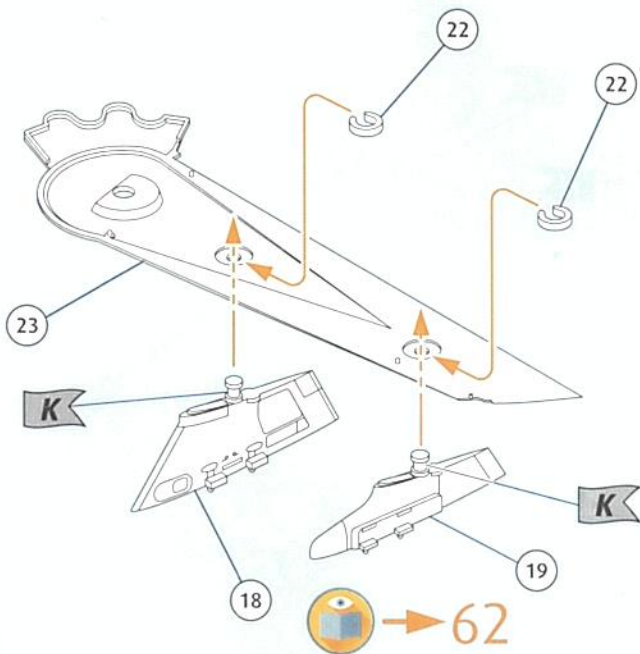
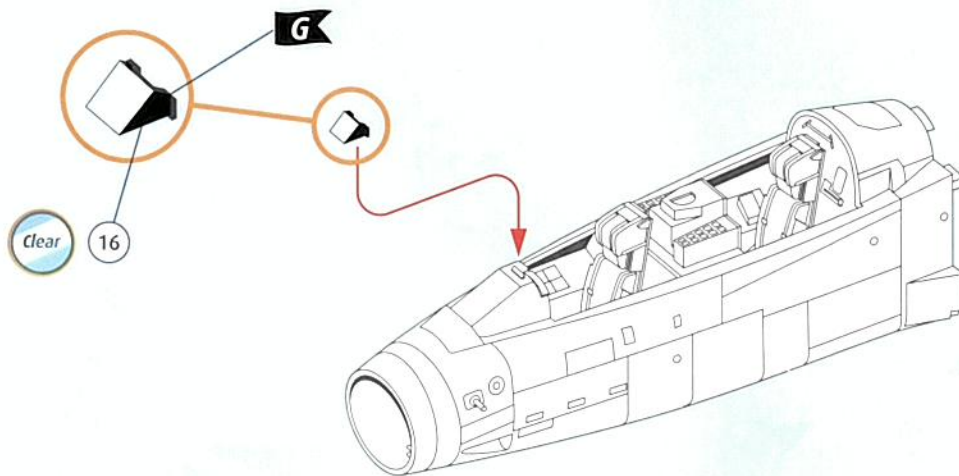
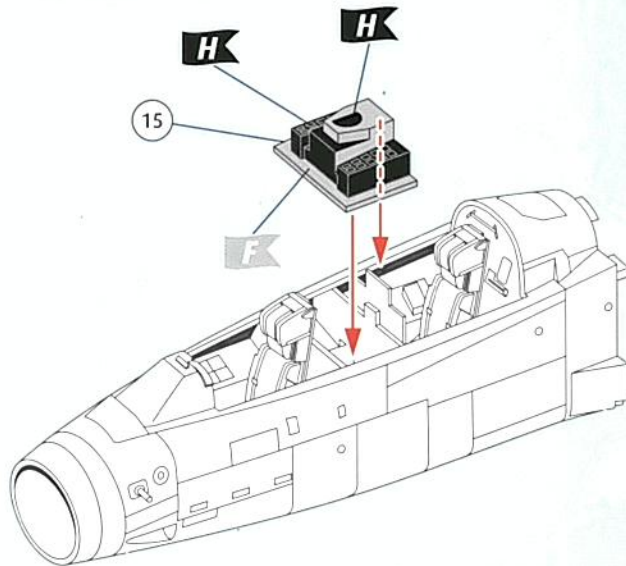

13

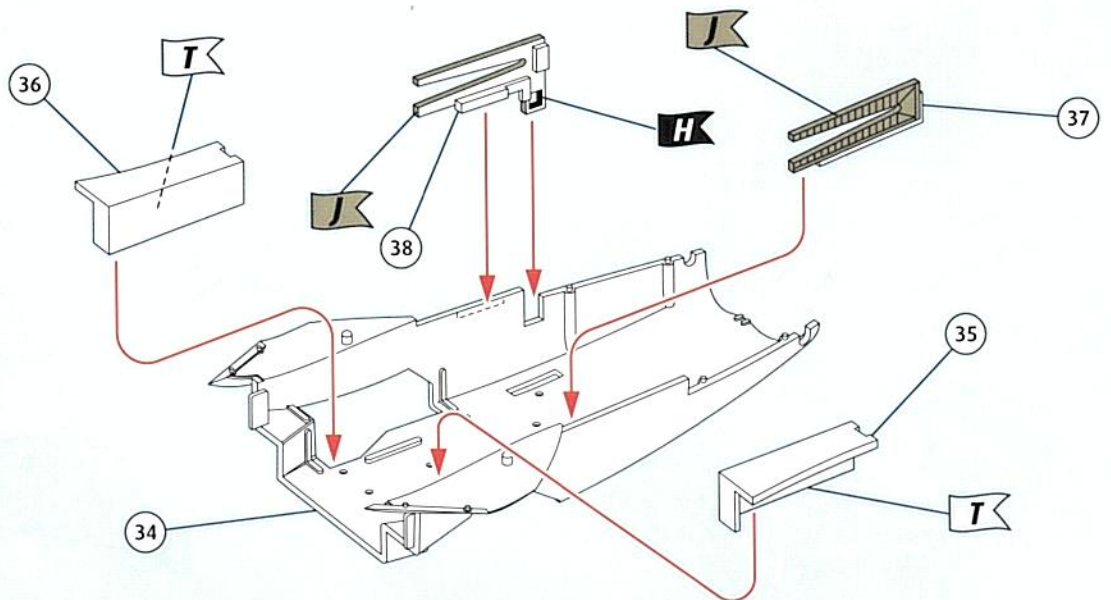
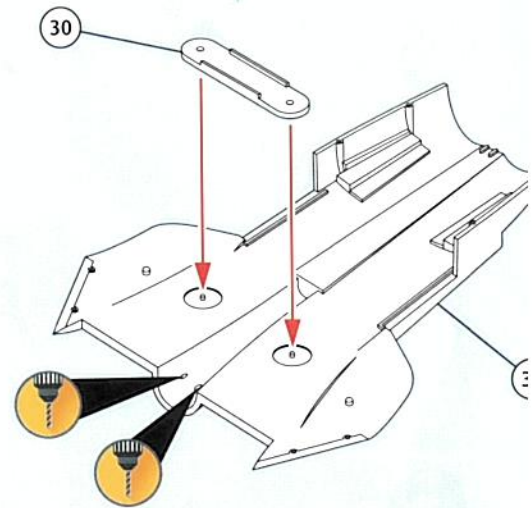
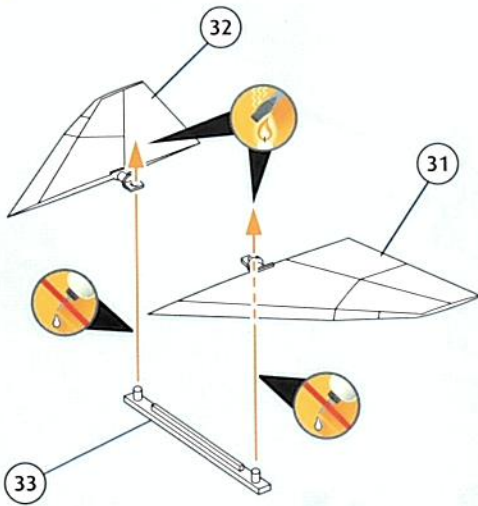
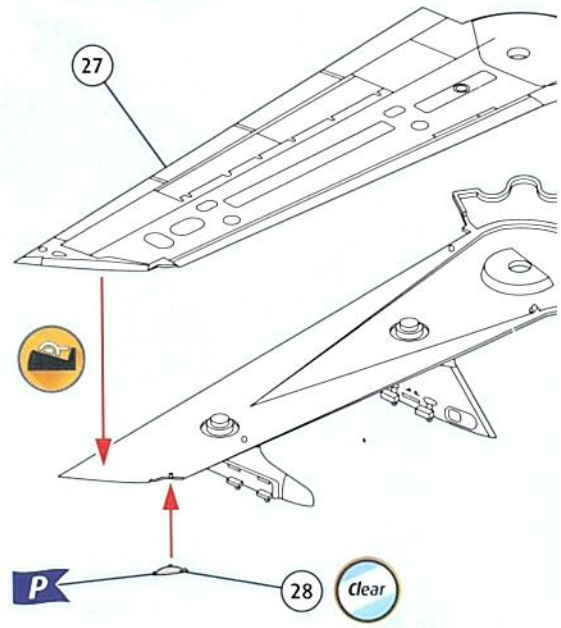
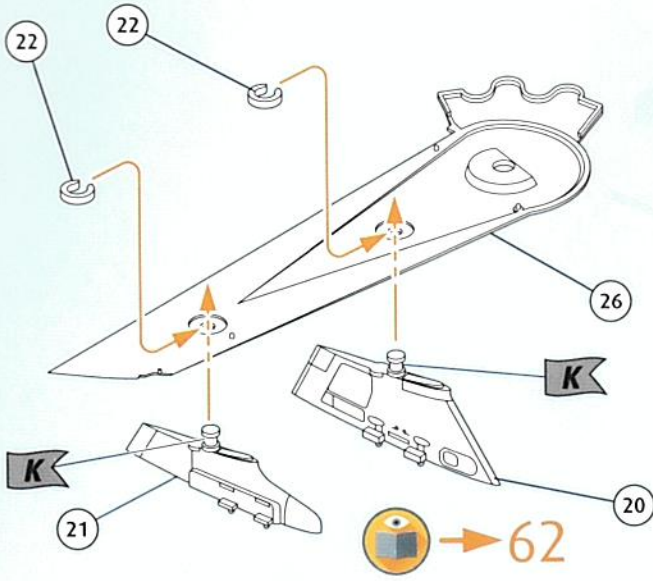

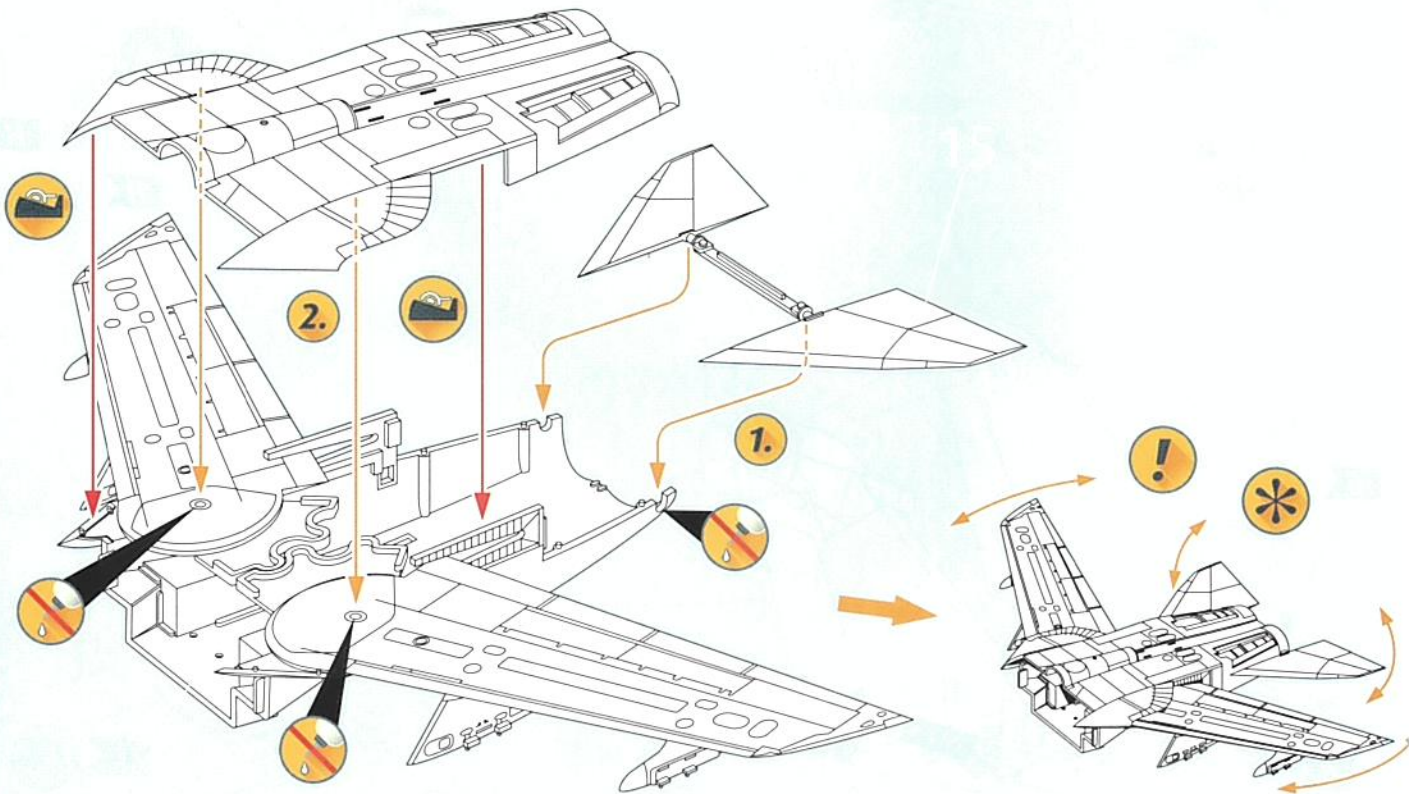
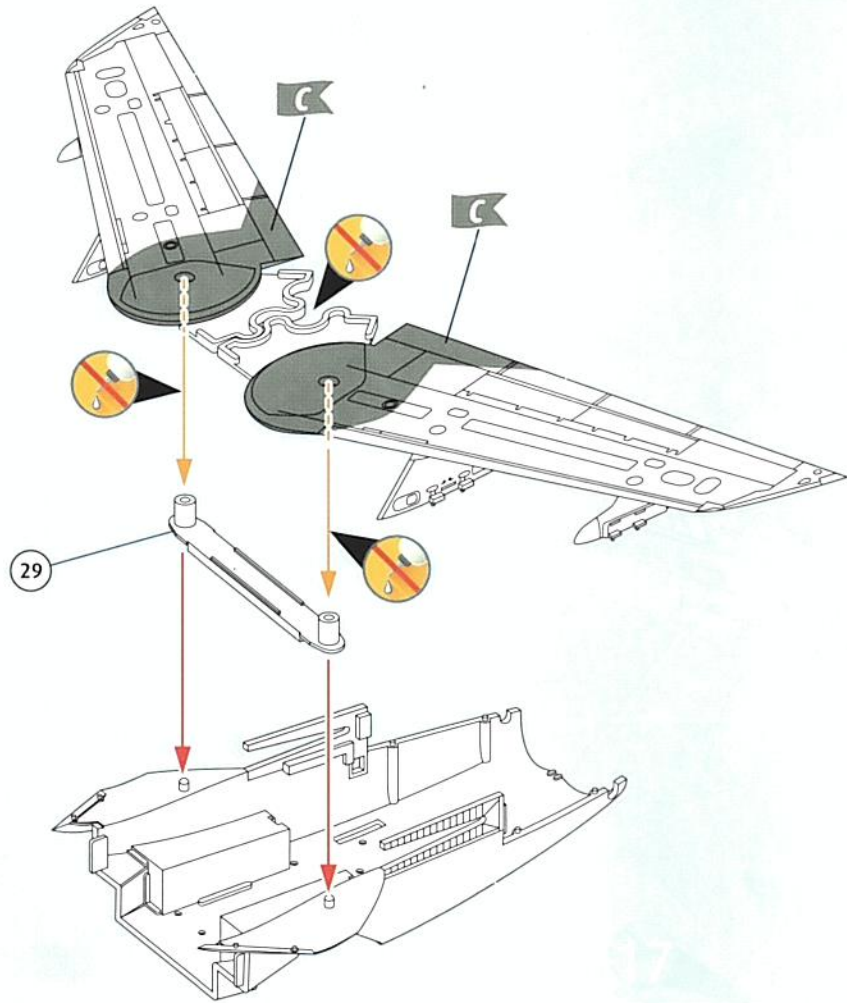

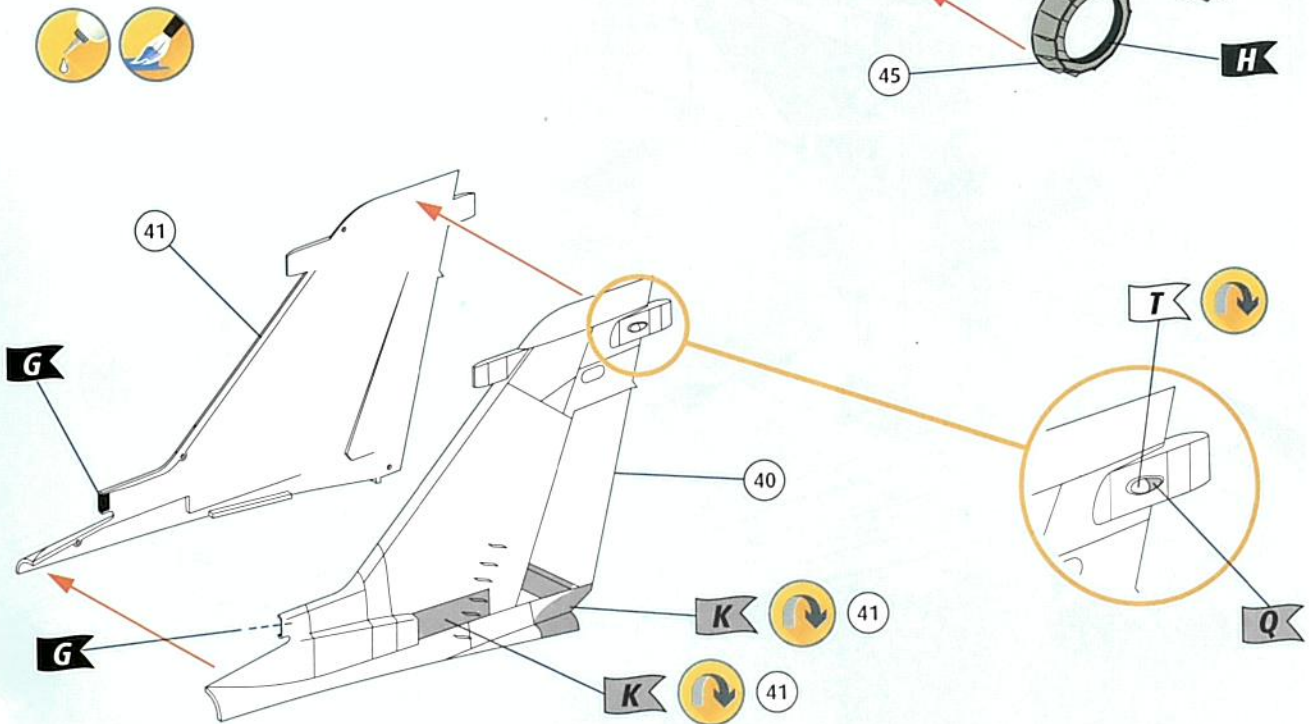
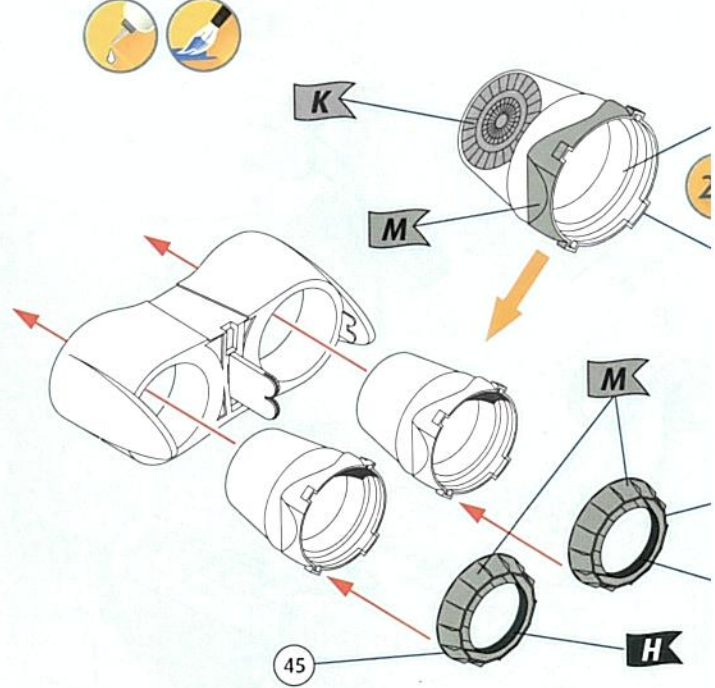
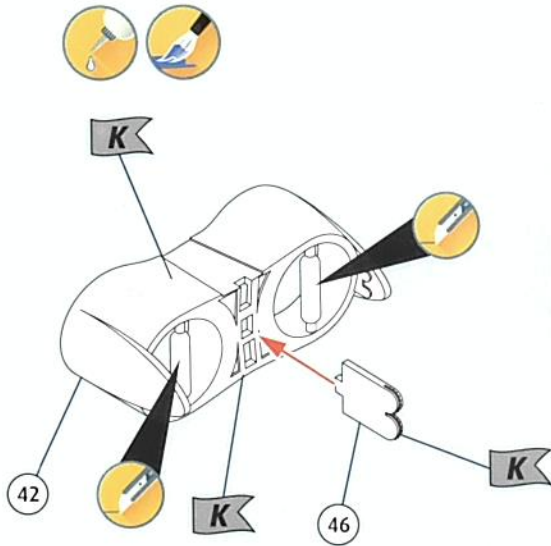
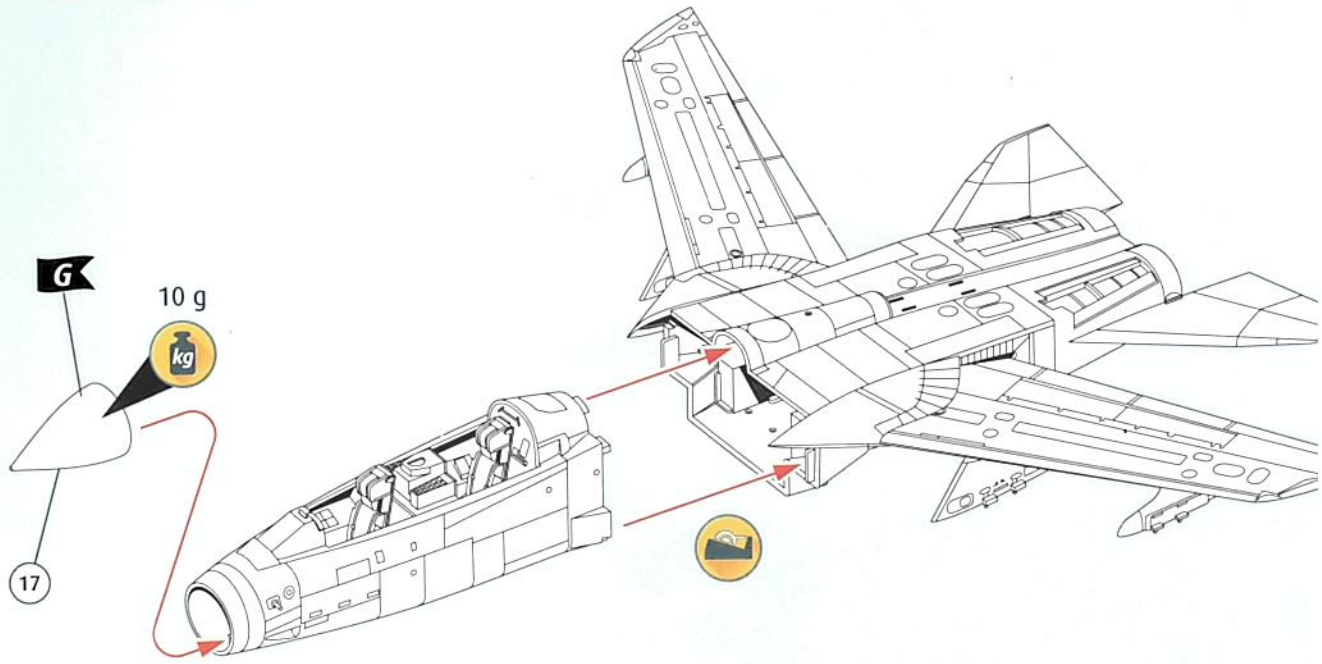

29

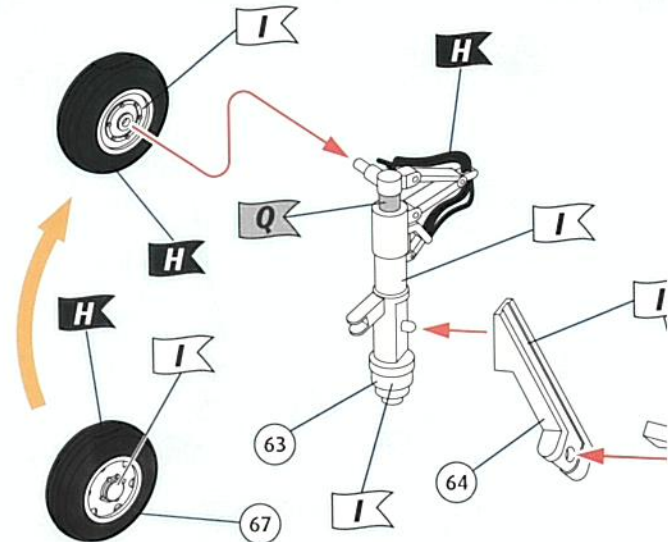
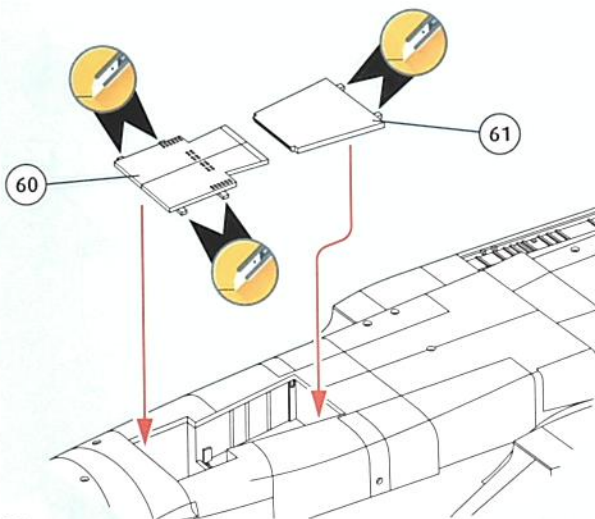
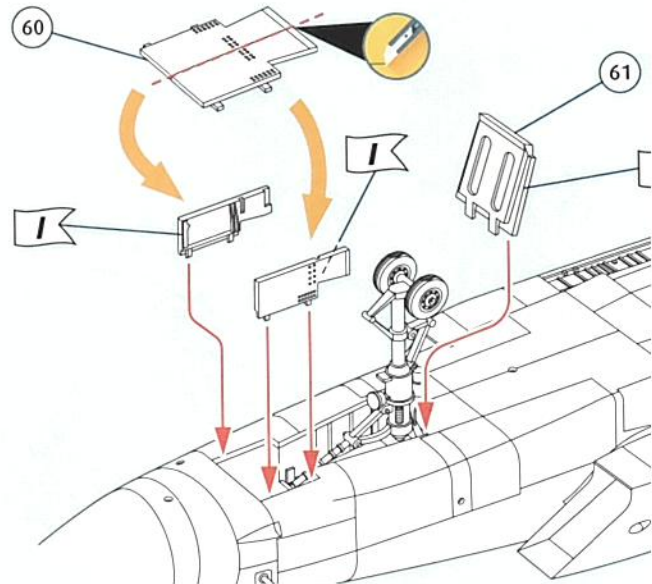
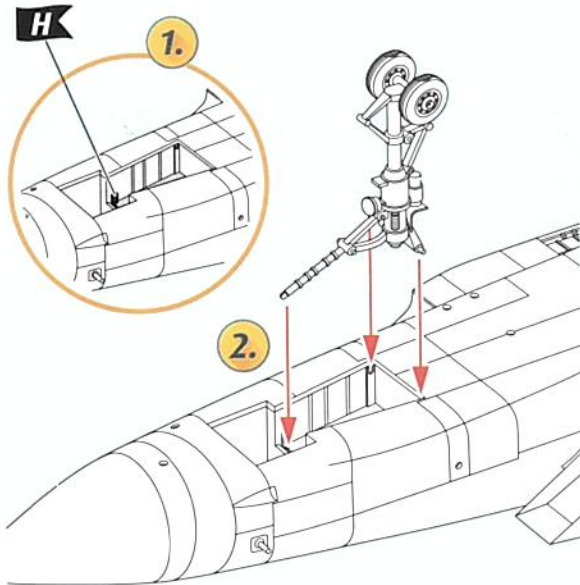
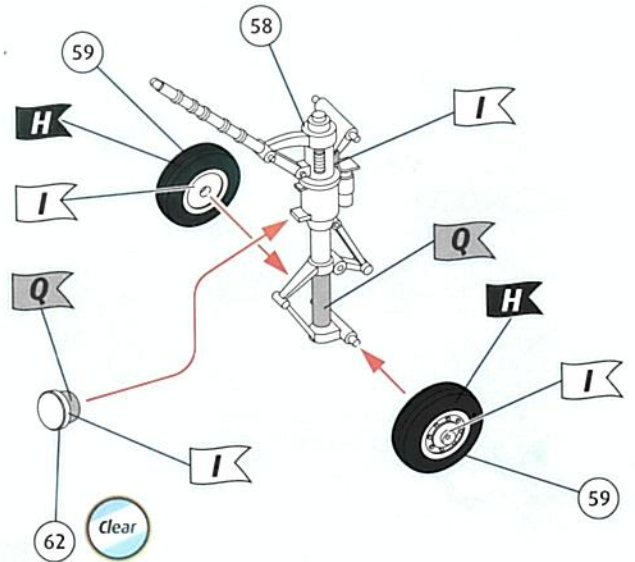
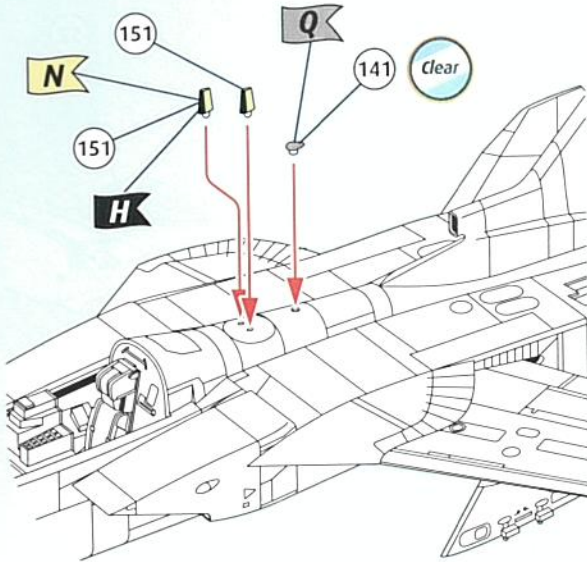

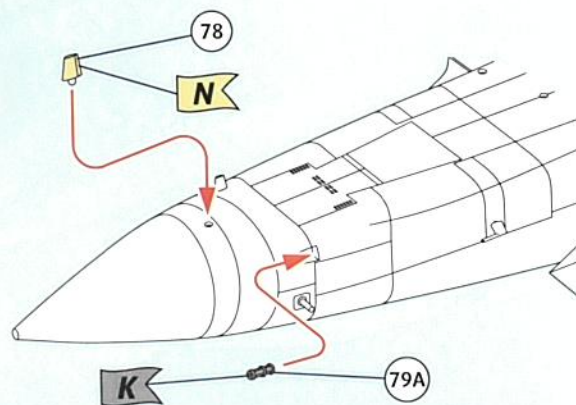
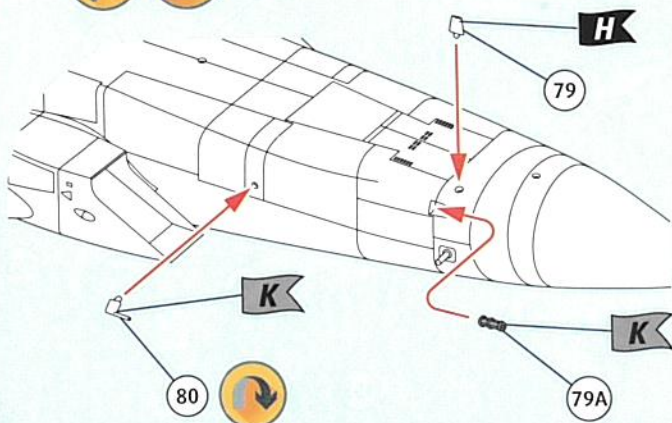
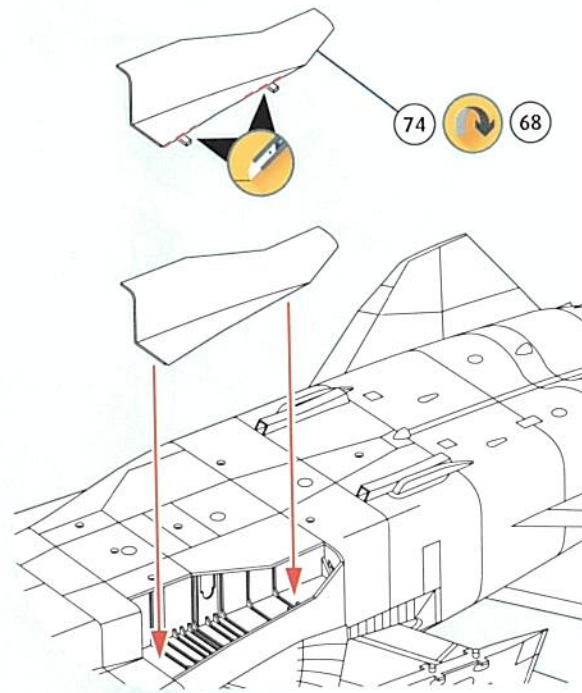
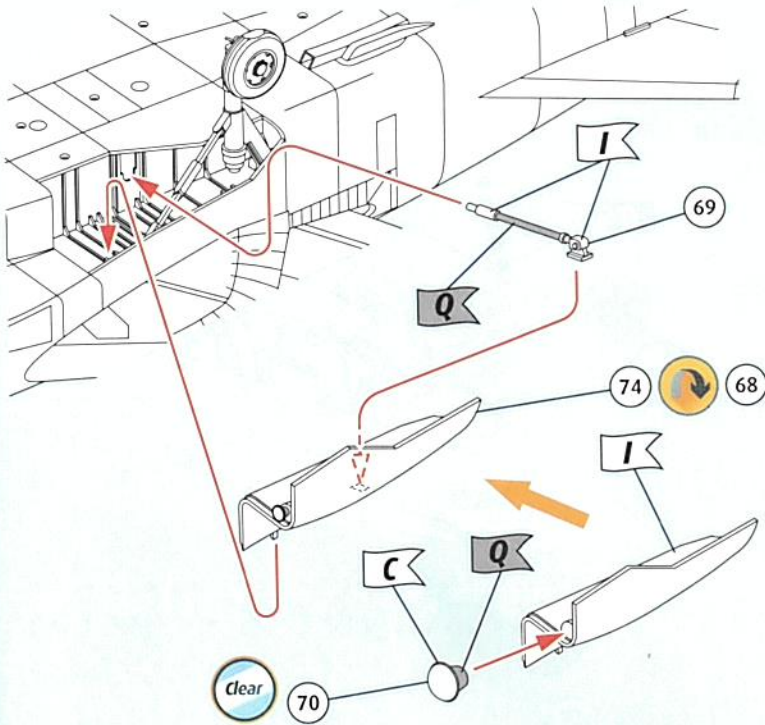
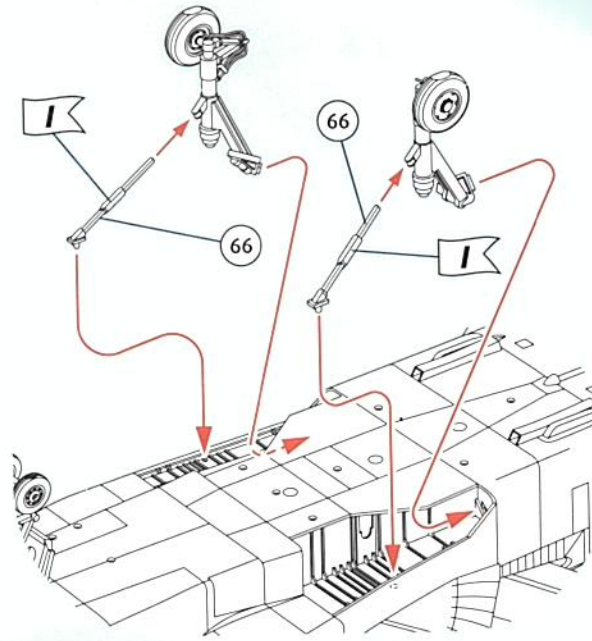
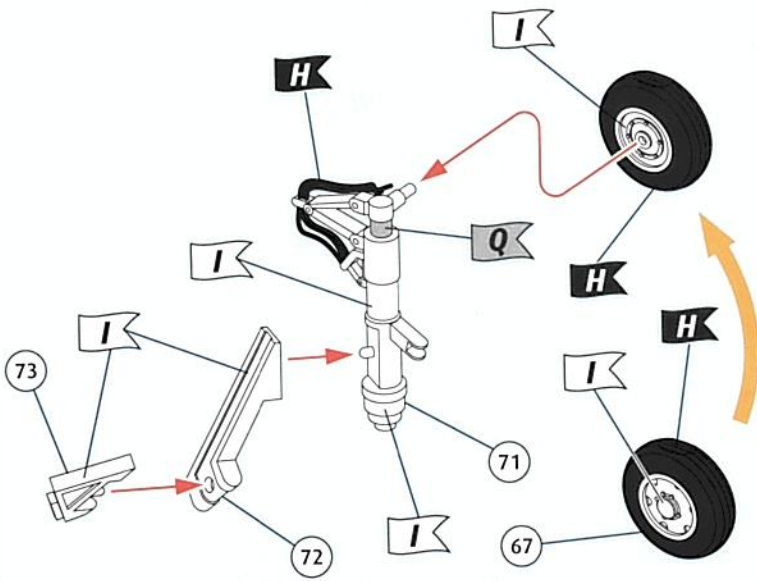

41



76

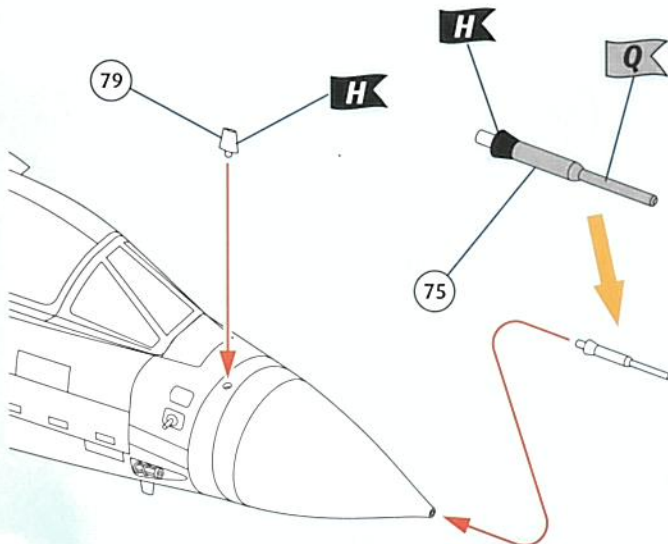
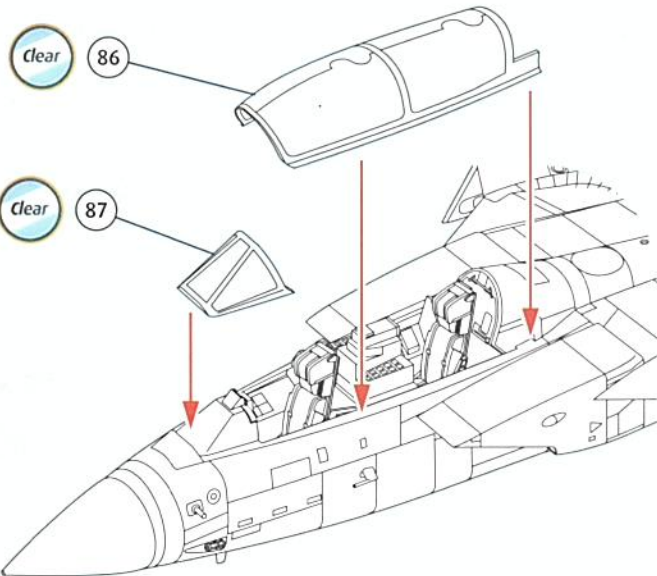
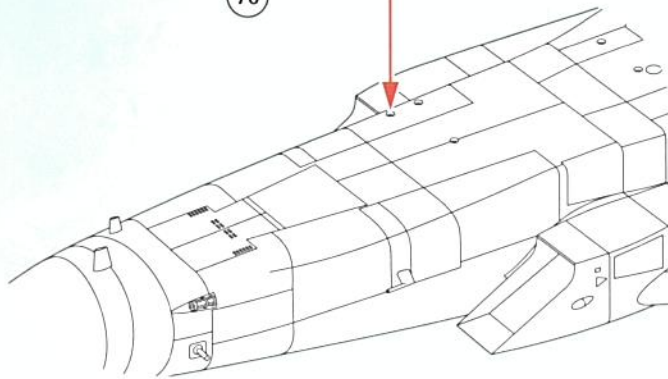

Clear 141

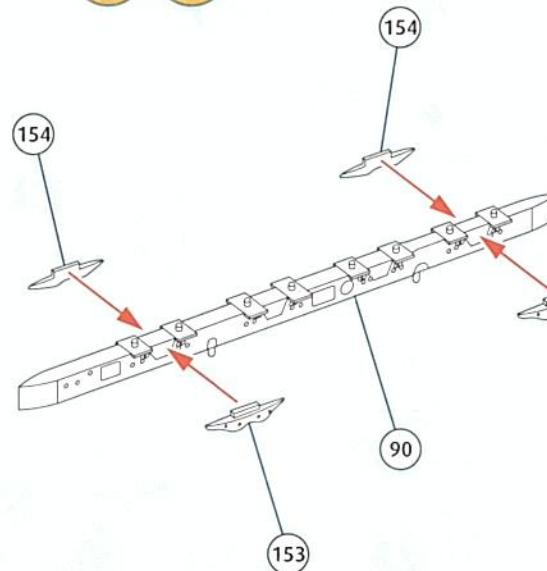
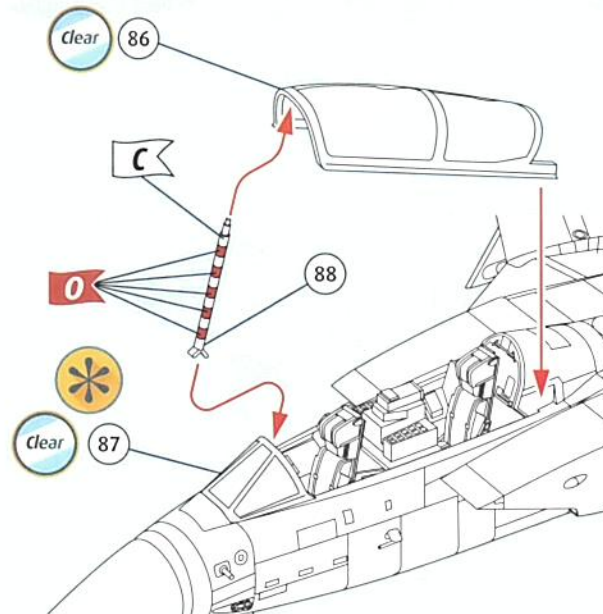
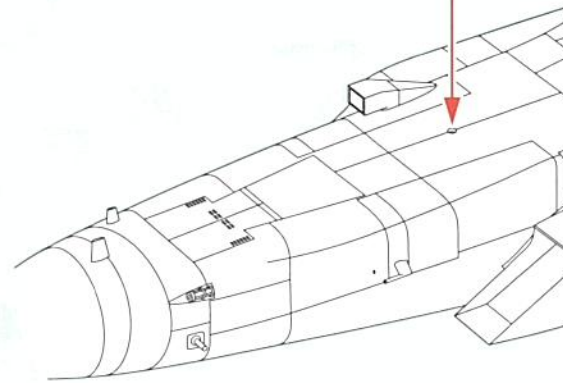

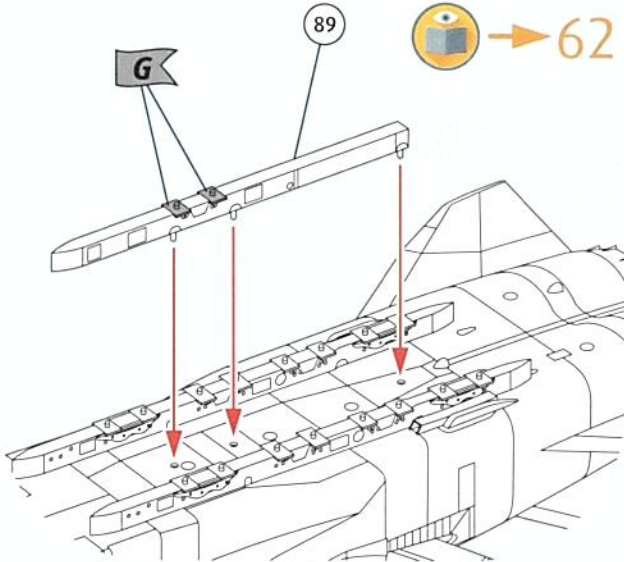
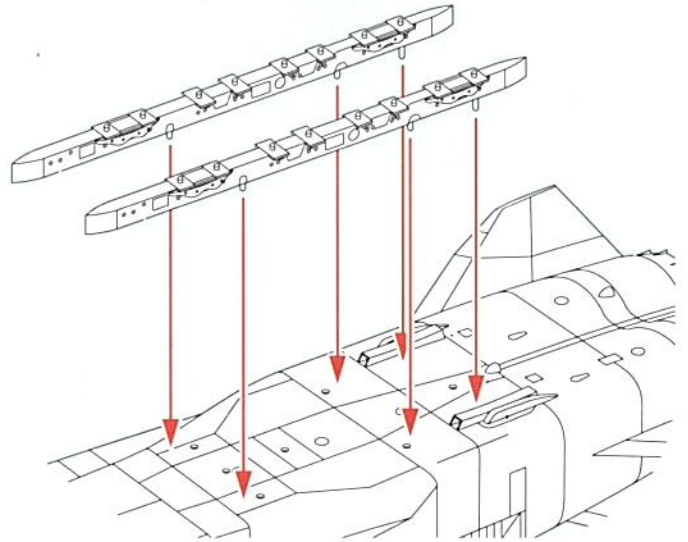
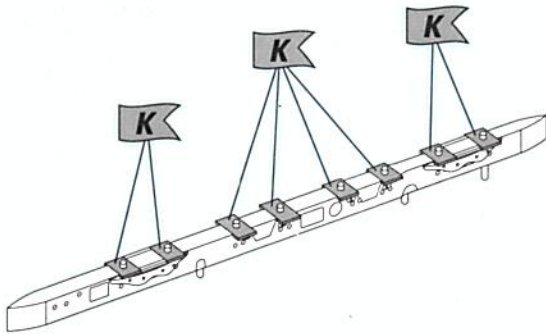

AIM-9L Sidewinder

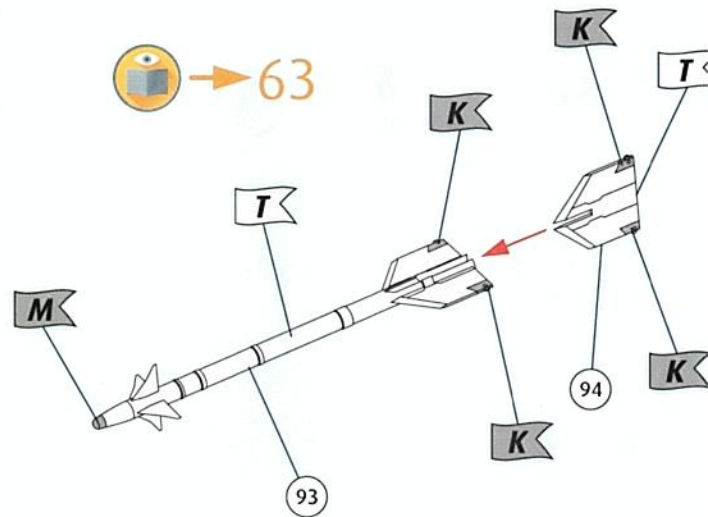

1500 Ltr. Fuel tank

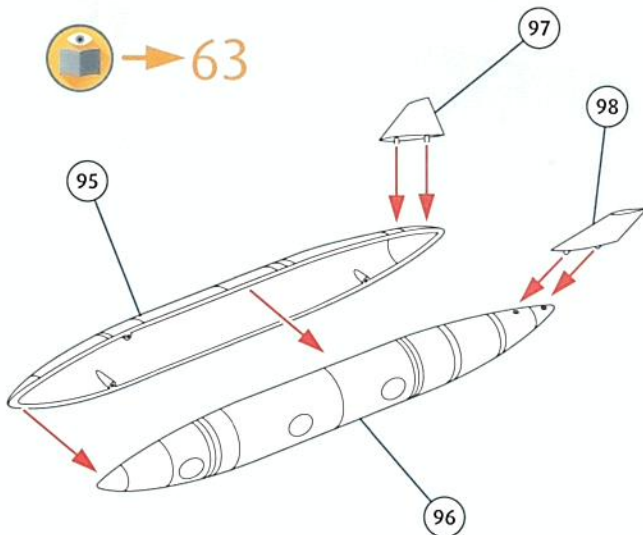

1500 Ltr. Fuel tank

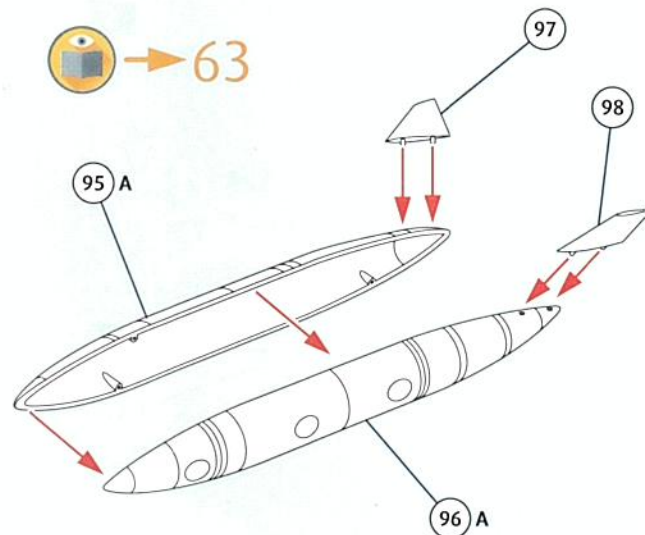

53



BOZ 107 counter-measures pod

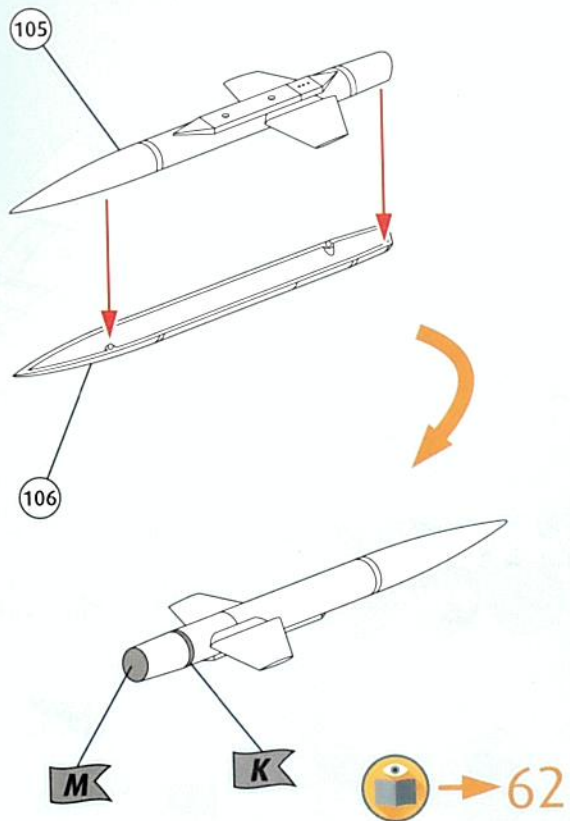

Sky Shadow ECM pod

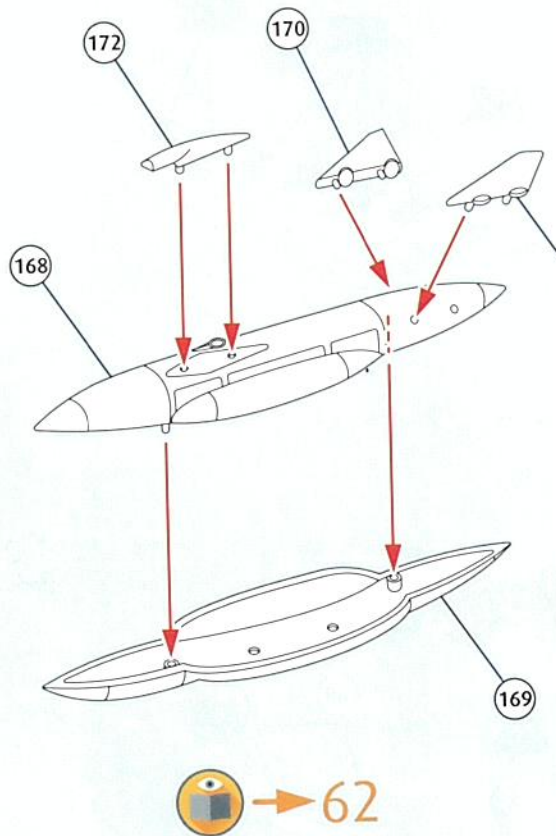

1000 lb bomb

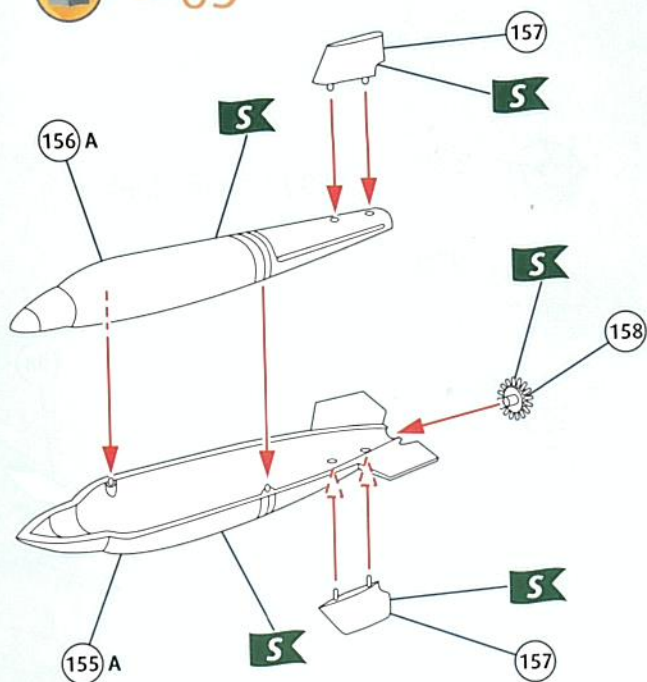

1000 lb bor

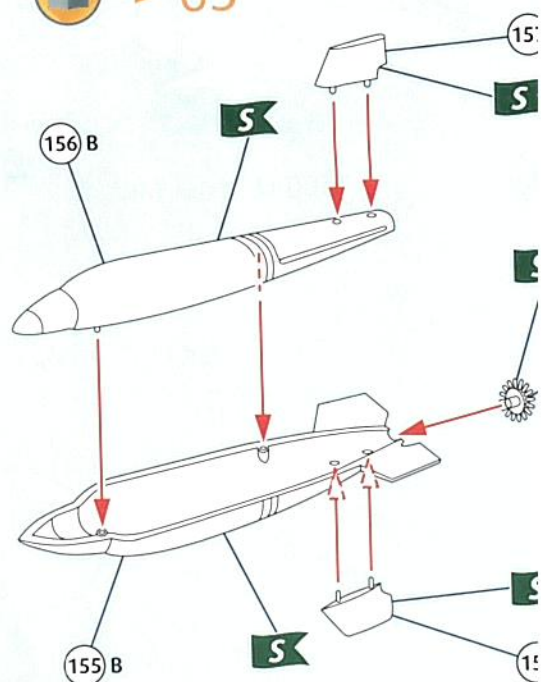

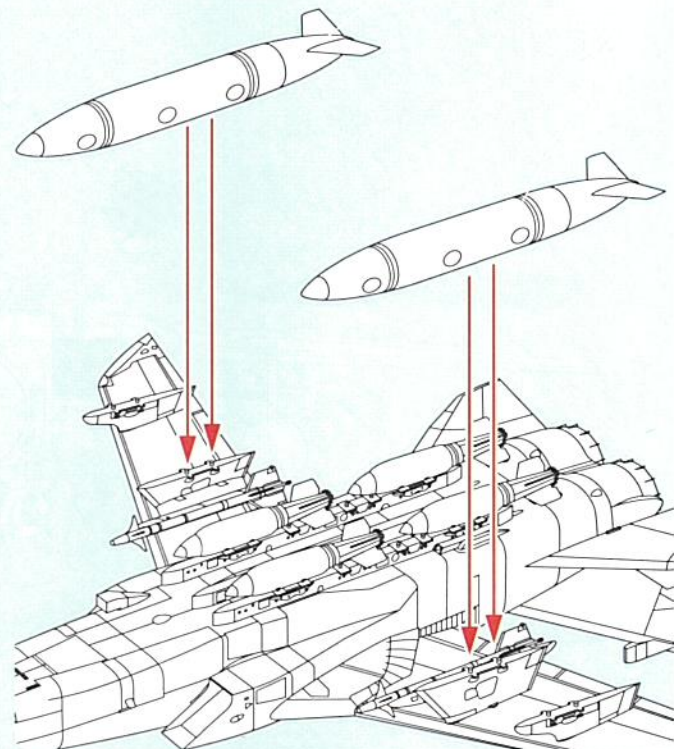
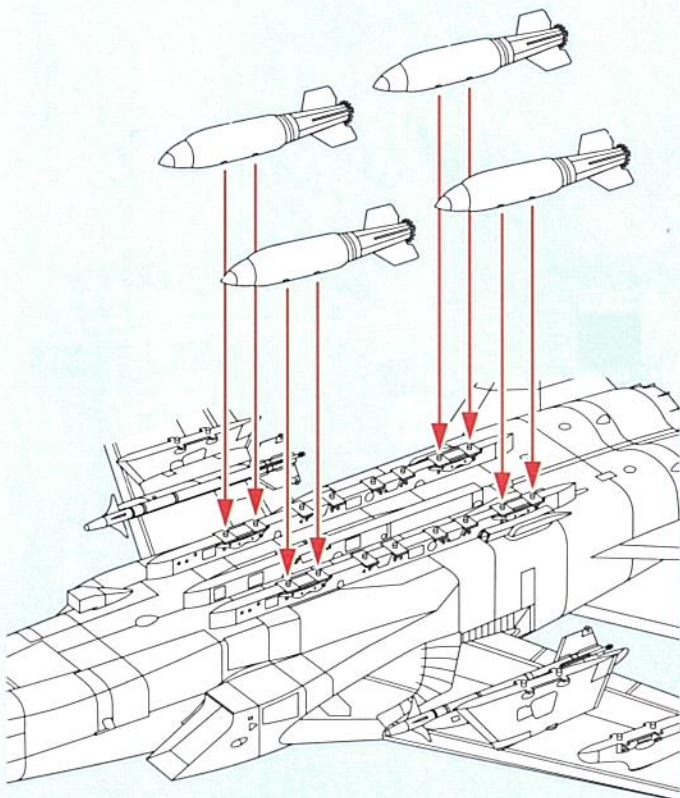
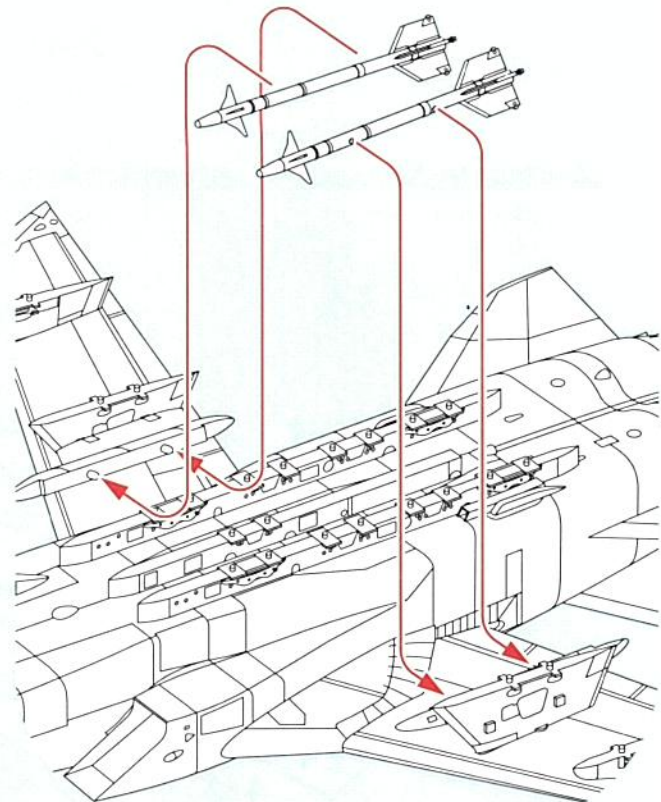
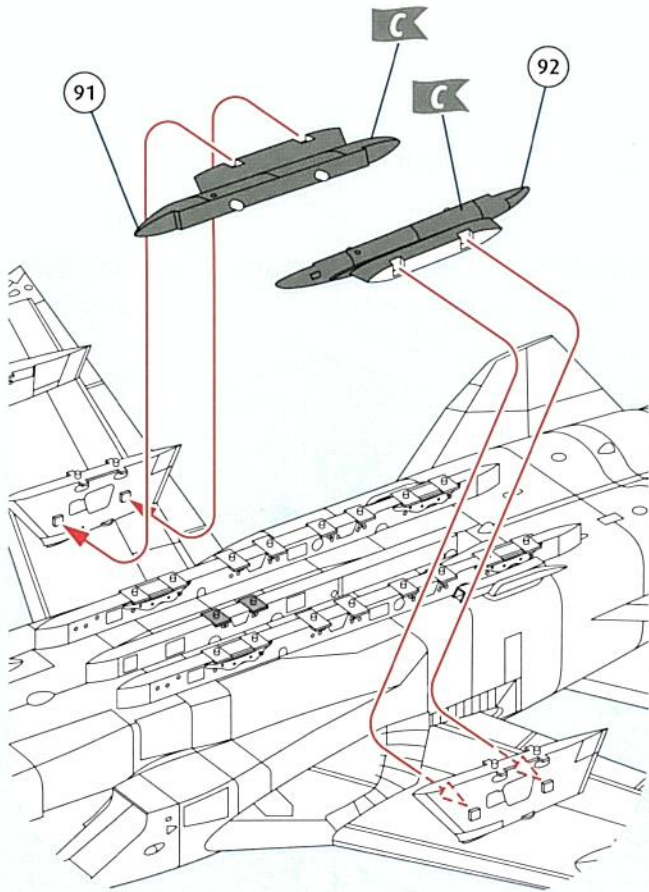

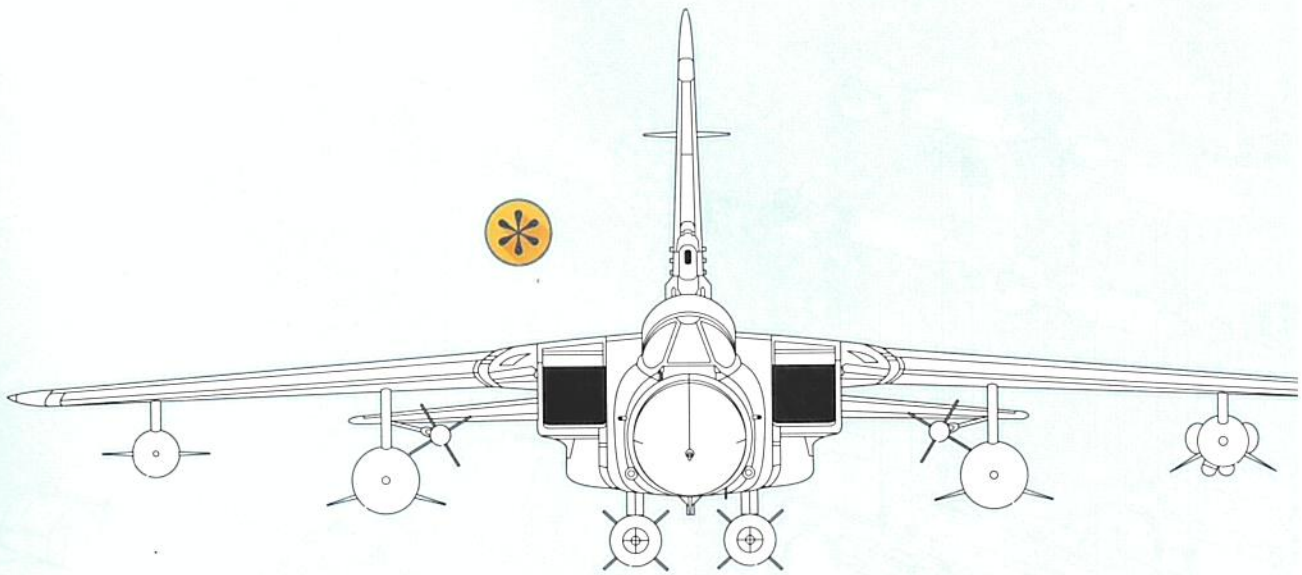
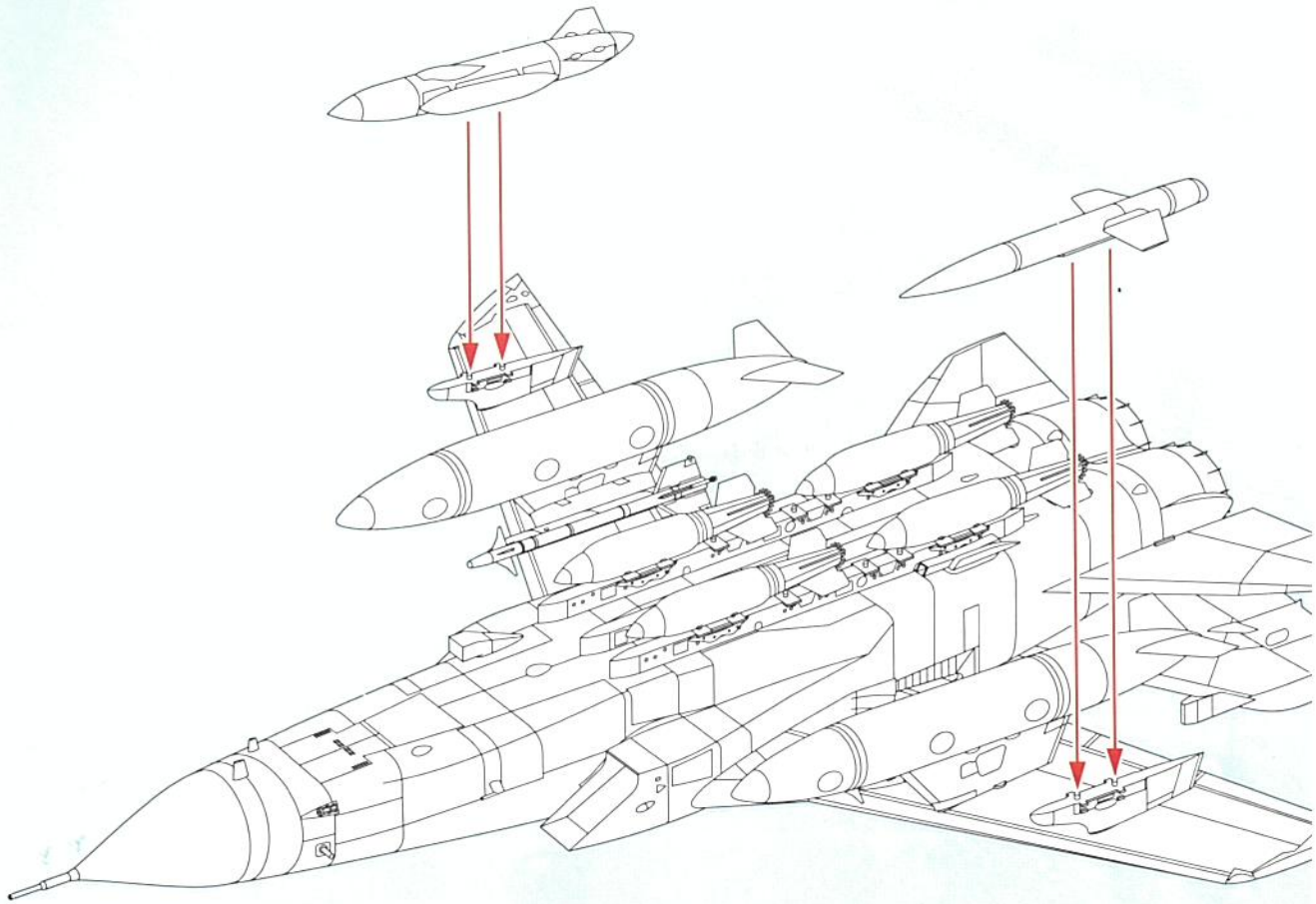



## pylons, weapons & stores

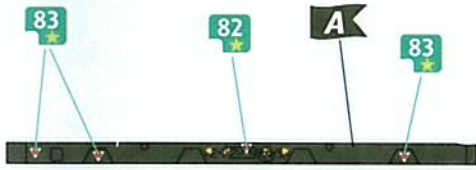

Left outboard fuselage pylon (outer face)



Left outboard fuselage pylon (inner face)



Central fuselage pylon (left side)



Right outboard fuselage pylon (outer face)

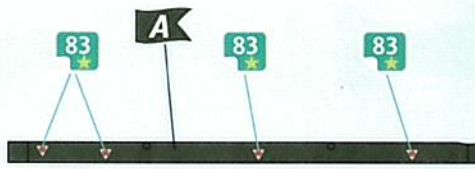

Right outboard fuselage pylon (inner face)



Central fuselage pylon (right side)

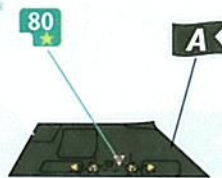

Right inboard wing pylon (outer face)

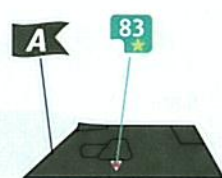

Right inboard wing pylon (inner face)

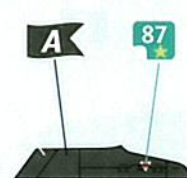

Right outboard wing pylon (outer face)



Right outboard wing pylon (inner face)

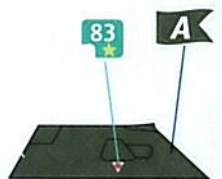

Left inboard wing pylon (inner face)

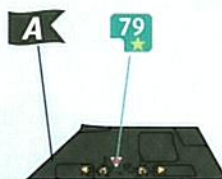

Left inboard wing pylon (outer face)



Left outboard wing pylon (inner face)



Left outboard wing pylon (outer face)

## Sky Shadow pod

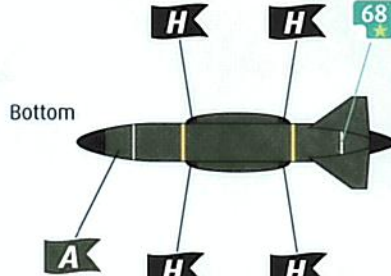
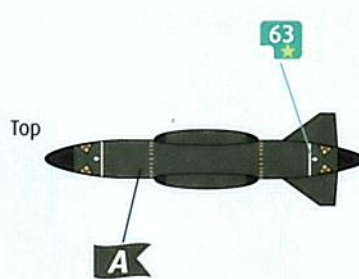
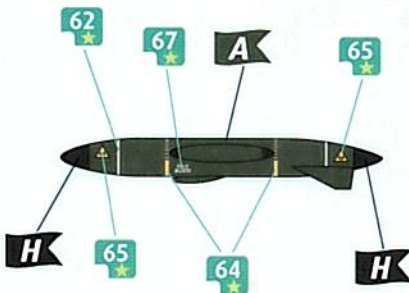

## BOZ 107 ECM pod

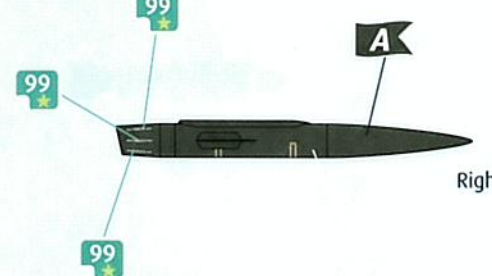



### pylons, weapons & stores

**2X** 1500 ltr fuel tank

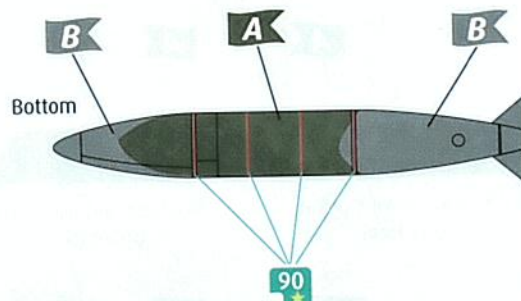
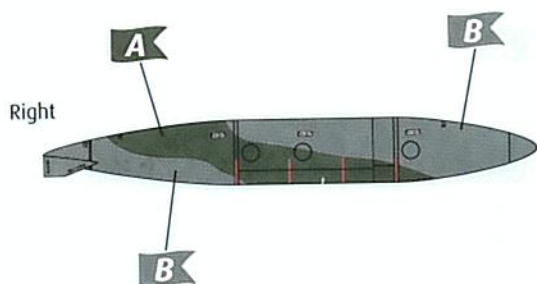
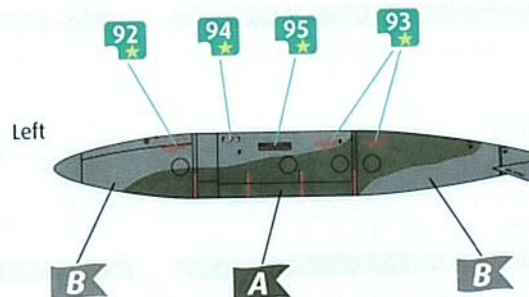
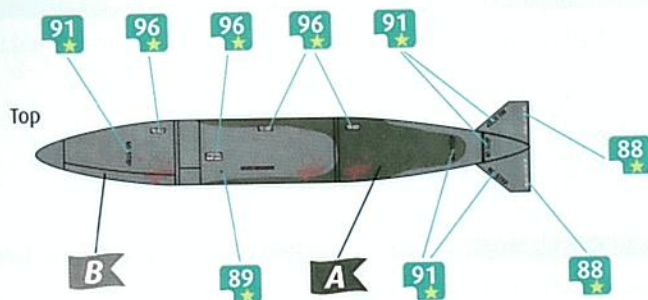

**2X** AIM-9L Sidewinder

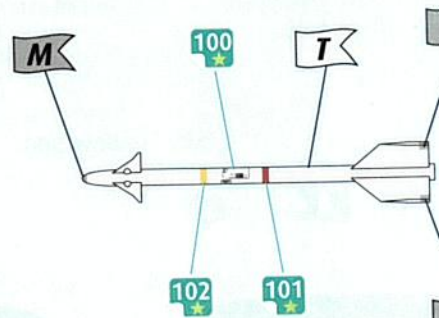

**4X** 1000 lb. bomb

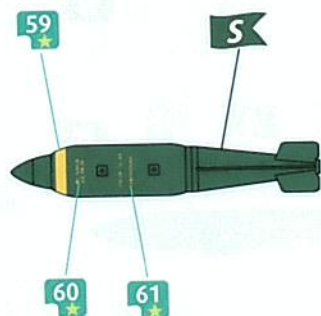

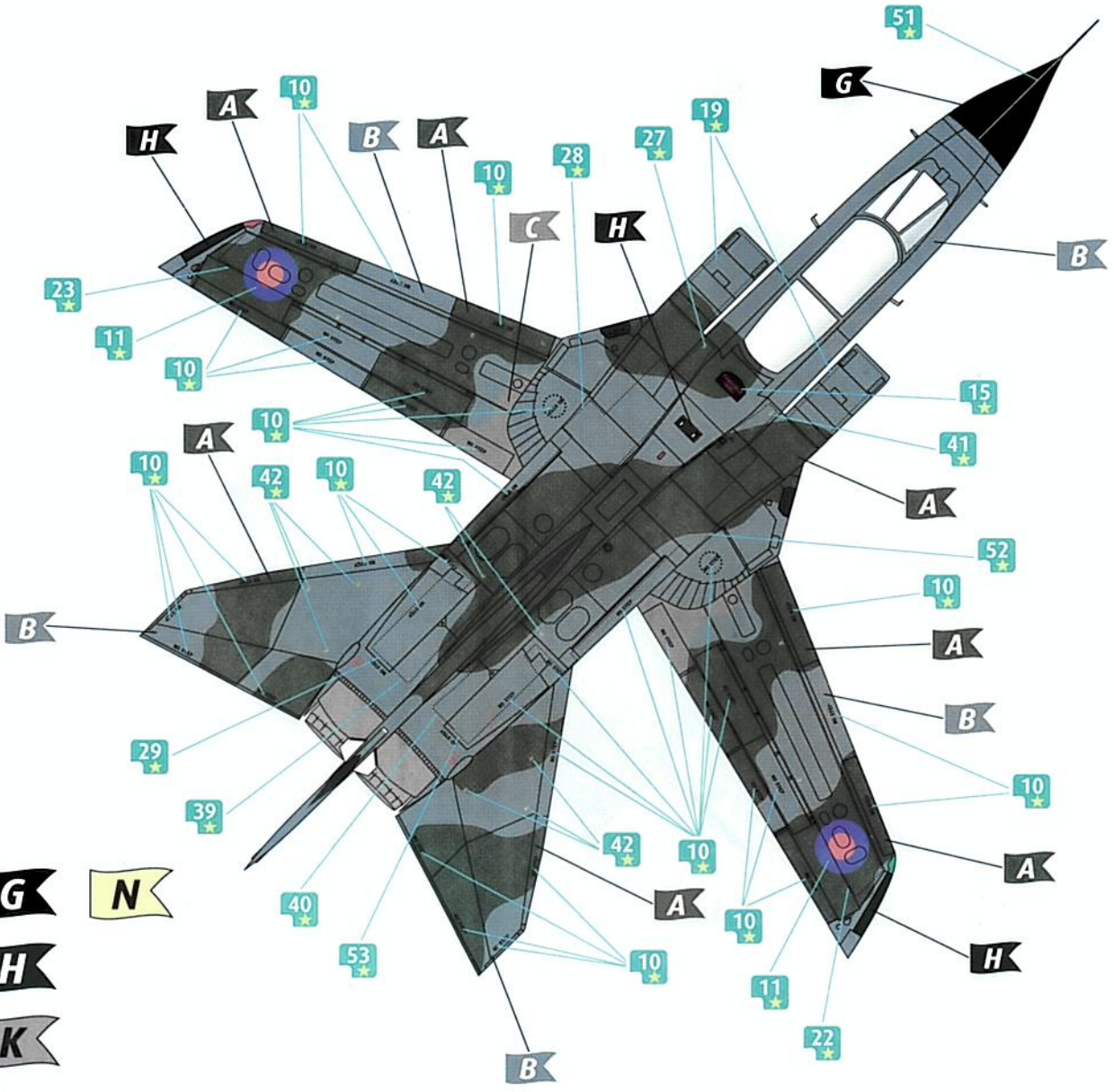
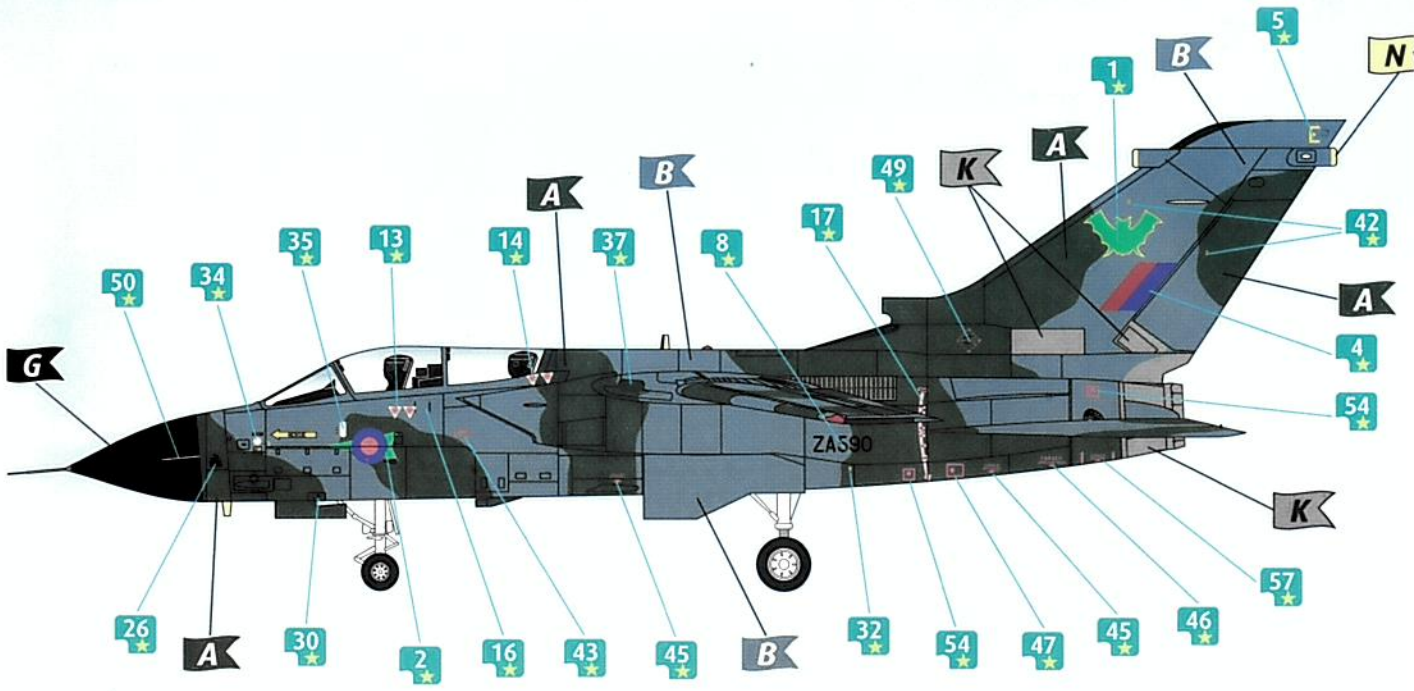

- |          |          |          |
|----------|----------|----------|
| <b>A</b> | <b>G</b> | <b>N</b> |
| <b>B</b> | <b>H</b> |          |
| <b>C</b> | <b>K</b> |          |

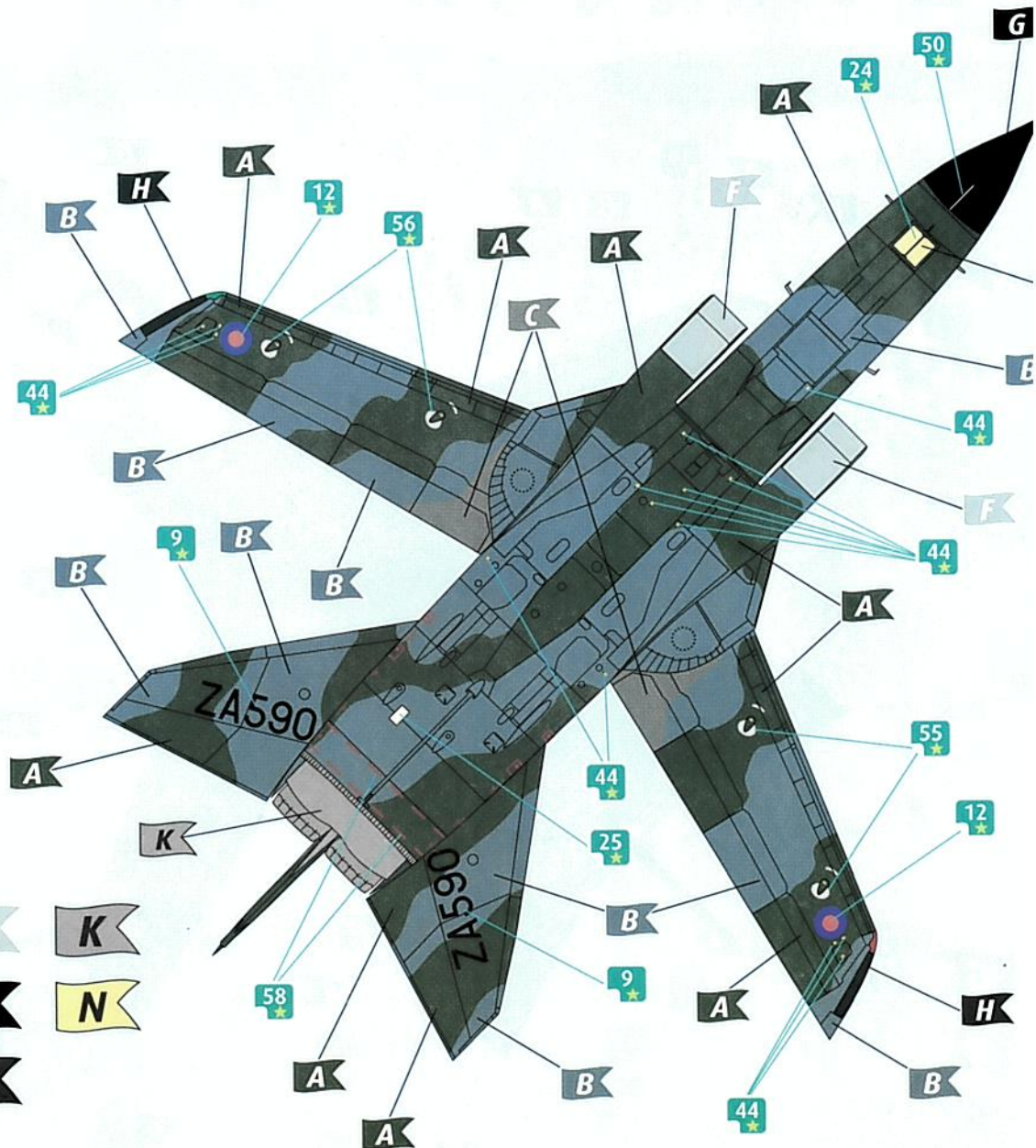
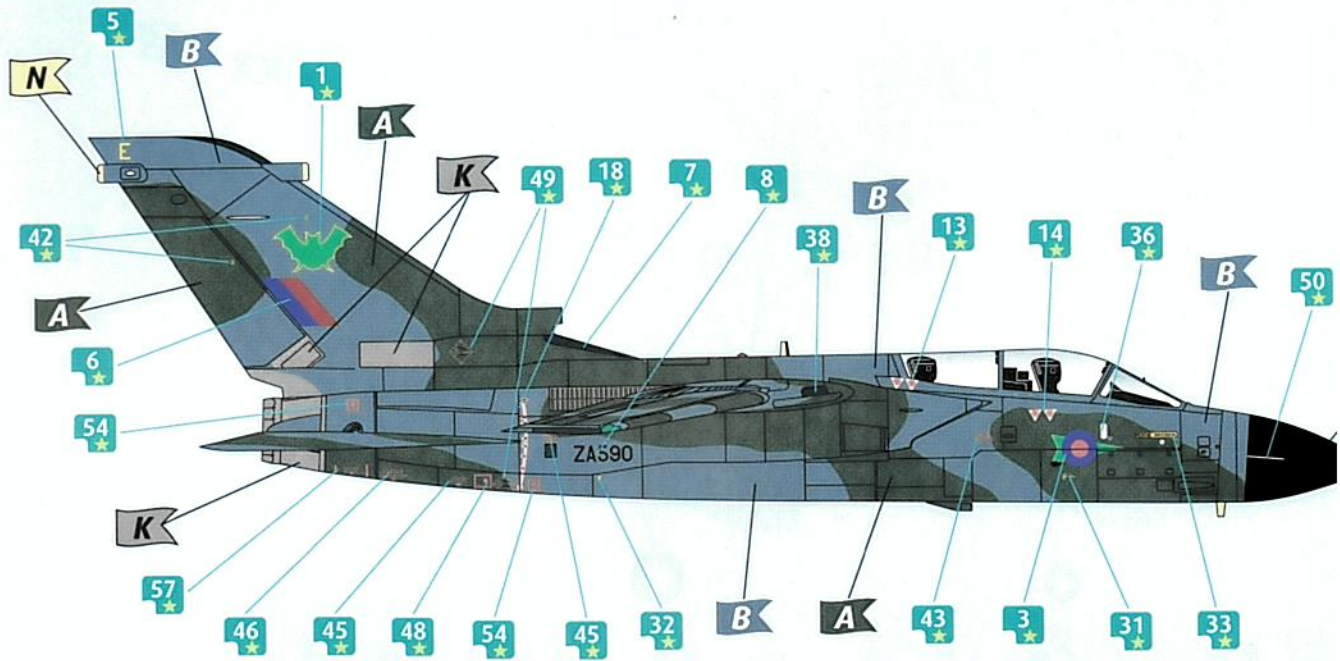

- |          |          |          |
|----------|----------|----------|
| <b>A</b> | <b>F</b> | <b>K</b> |
| <b>B</b> | <b>G</b> | <b>N</b> |
| <b>C</b> | <b>H</b> |          |



03801-0379

LEVEL 4  
1 2 3 4 5

# TORNADO IDS

Beiliegenden Sicherheitstext beachten / Please note the enclosed safety advice

- Ⓞ Beiliegenden Sicherheitstext beachten und nachschlagbereit halten.
- Ⓞ Please note the enclosed safety advice and keep safe for later reference.
- Ⓞ Respecter les consignes de sécurité ci-jointes et les conserver à portée de main.
- Ⓞ Houdt u aan de bijgaande veiligheidsinstructies en hou deze steeds bij de hand.
- Ⓞ Seguire le avvertenze di sicurezza allegate e tenerle a portata di mano.
- Ⓞ Observar y siempre tener a disposición este texto de seguridad adjunto.
- Ⓞ Ter em atenção o texto de segurança anexo e guardá-lo para consulta.

- Ⓞ Overhold vedlagte sikkerhedsanvisninger og hav dem liggende i nærheden.
- Ⓞ Ha alltid vedlagt sikkerhetstekst klar til bruk.
- Ⓞ Beakta bifogad säkerhetstext och håll den i beredskap.
- Ⓞ Huomioi ja säilytä oheiset varoitukset.
- Ⓞ Соблюдать технику безопасности, сохранить инструкцию для дальнейших обращений.
- Ⓞ Przestrzegać załączonego tekstu dotyczącego bezpieczeństwa i mieć go zawsze pod ręką.
- Ⓞ Dodržujte tento příložený bezpečnostní text a mějte ho po ruce.
- Ⓞ A mellékelt biztonsági szöveget vegye figyelembe és tartsa fellepozásra készen.

- Ⓞ Respektujte příložený bezpečnostný text a uchovajte ho pre budúce použitie.
- Ⓞ Respectați textul de siguranță atașat și păstrați-l la îndemână.
- Ⓞ Спазвайте приложениа текст за безопасност и го дръжте под ръка за справки.
- Ⓞ Priložena varnostna navodila izvajajte in jih hranite na vsem dostopnem mestu.
- Ⓞ Λάβετε υπόψη σας το συνημμένο κείμενο ασφαλείας και φυλάξτε το ώστε να ανατρέχετε σε αυτό όποτε χρειάζεται.
- Ⓞ Ektekiqüvenlik talimatlarını dikkate alıp, bakabileceğiniz bir şekilde muafaza ediniz.

© 2024 Carrera Revell Europe GmbH, Henschelstr. 20-30, D-32257 Bünde.

REVELL IS THE REGISTERED TRADEMARK OF CARRERA REVELL EUROPE GMBH, GERMANY. [www.revell.de](http://www.revell.de)

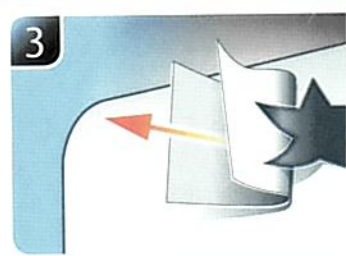
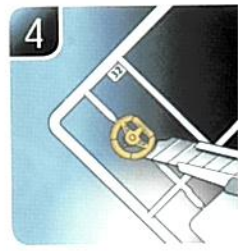
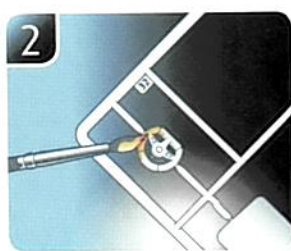
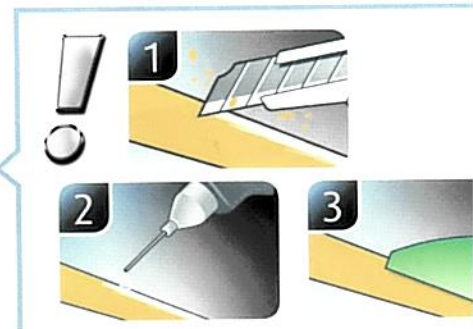
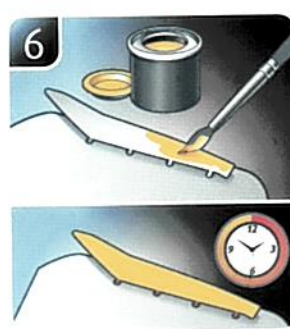
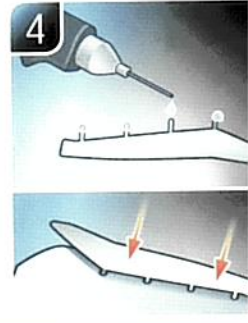
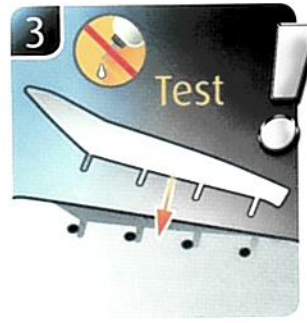
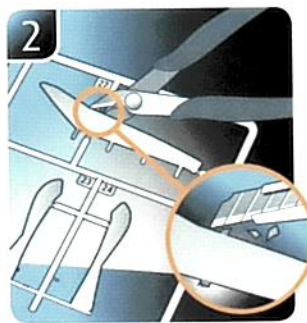
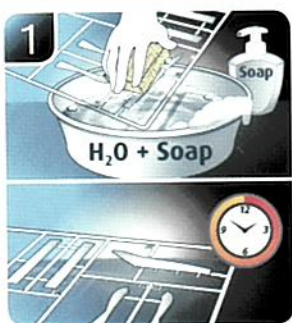
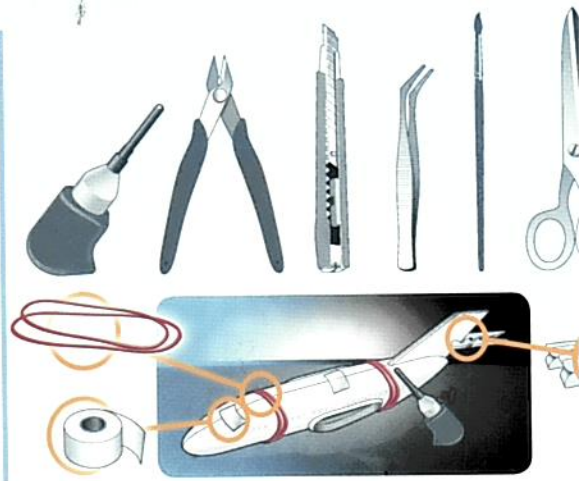
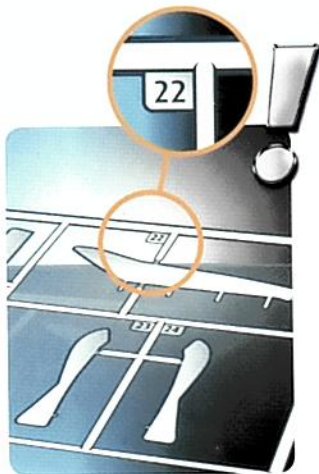

- DE Weitere Tipps und Tricks.
- GB Additional tips and tricks.
- FR Conseils et astuces supplémentaires.
- NL Andere tips en trucs.
- IT Ulteriori consigli e suggerimenti.
- ES Consejos y sugerencias adicionales.
- PT Mais dicas e truques.

- DE Flere tips og tricks.
- NO Flere tips og tricks.
- SE Ytterligare tips och tricks.
- FI Lisää vinkkejä ja niksejä.
- RU Другие советы и хитрости.
- PL Dalsze wskazówki i sugestie.
- CZ Další tipy a rady.
- HU További ötletek és fogások.
- SK Ďalšie tipy a triky.
- RO Alte sfaturi și trucuri.

- DE Други полезни съветове.
- SE Nadaljnji nasveti in ;
- FR Προσθετες συμβουλες ;
- PL Diger öneriler ve ipu

www.revell.



- ☞ Spitze eines Schraubenziehers erhitzen und auf das herausragende Ende des Plastikstiftes drücken.
- ☞ Heat tip of screwdriver and press on protruding end of plastic pin.
- ☞ Chauffer la pointe du tournevis et appuyer sur la partie saillante de l'extrémité en plastique.
- ☞ De punt van een schroevendraaier verhitten en op het uitstekende einde van de plastic stift drukken.
- ☞ Riscaldare la punta di un cacciavite e premere sull'estremità sporgente del perno di plastica.
- ☞ Calentar la punta del destornillador y presionar el extremo saliente de la clavija de plástico.
- ☞ Aquecer a ponta de uma chave de parafusos e pressionar sobre a extremidade protuberante do pino plástico.
- ☞ Opvarm spidsen af en skruestrækker og tryk på den udragende ende af plastikstiften.
- ☞ Varm opp spissen på en skruestrøker og trykk på den utstikkende enden av plaststiften.
- ☞ Värm toppen av en skruvmejsel och tryck den på plaststiftens utstickande ände.
- ☞ Kuumenna ruuvimeisselin päättä ja paina esiintyntyvän muovipuikon päätä.
- ☞ Нагреть наконечник отвертки и надавить на выступающий конец пластмассового штифта.
- ☞ Ogrzać czubek śrubokrętu i przycisnąć do końcówki wystającego plastikowego kolka.
- ☞ Náhrejte špičku šroubováku a přitiskněte ji na vyčnívající konec plastového kolíku.
- ☞ Melegitse meg a csavarhúzó hegyét és nyomja rá a műanyag csap kiálló végére.
- ☞ Zohrejte hrot škrutkovača a zatlačte na vyčnívající koniec plastového kolíka.
- ☞ Incălziiți vârful unei șurubelnițe și apăsați pe capătul proeminent al știftului de plastic.
- ☞ Нагрейте връха на отвертка и натиснете подаващия се край на пластмасовия шифт.
- ☞ Konicno izvijača segrejte in pritisnite na izstopajoči konec plastičnega zatiča.
- ☞ Οερμάτωση μύτη ενός καταβιδιού και πιέστε στο άκρο του πλαστικού πείρου που προεξέχει.
- ☞ Tornavidanın ucunu ısıtin ve plastik pimini çikinti yapan ucuna tutun.



- ☞ Abziehbild in Wasser einweichen und anbringen.
- ☞ Soak and apply decals.
- ☞ Mouiller et appliquer les décalcomanies.
- ☞ Transfer in water even laten weken en aanbrengen.
- ☞ Immergere la decalcomania nell'acqua e applicarla.
- ☞ Mojar y aplicar calcomanias.
- ☞ Amolecer o decalque em água e aplicar.
- ☞ Gör överföringsbilledet vådt og sæt det på.
- ☞ Myk opp avtrekkingsbildet i vann og sett det på.
- ☞ Blotlagg dekalen i vatten och sätt på den.
- ☞ Pehmitä siirtokuvaa vedessä ja siirrä paikkaan.
- ☞ Опустите переводную картинку в воду и прикрепите ее.
- ☞ Namoczyc kalkomanie w wodzie i przyklej.
- ☞ Nechte obtisk odmočit ve vode a přilepte.
- ☞ Meritse vízbe és helyezze fel a matricát.
- ☞ Obtlačkovy obrázok namočte do vody a priložite.
- ☞ Inmuiati abtîbildul în apă și aplicați-l.
- ☞ Потопете ваденката във вода и я поставете.
- ☞ Prelepnicu namakajte v vodi. In namestiti.
- ☞ Μουσκεψτε σε νερό και τοποθετήστε τις ετικέτες.
- ☞ Çikartmayı suda yumuşatın ve takın.



\*

- ☞ Zur Anbringung der Abziehbilder empfohlen.
- ☞ Recommended for affixing the decals.
- ☞ Recommandé pour l'application des décalcomanies.
- ☞ Aanbevolen voor het aanbrengen van de transfers.
- ☞ Raccomandato per l'applicazione delle decalcomanie.
- ☞ Recomendado para fijar bien las calcomanias.
- ☞ Recomendado para a fixação dos autocolantes.
- ☞ Anbefales til anbringelse af overføringsbillederne.
- ☞ Anbefales til å feste avtrekksbilder.
- ☞ Rekommenderad för montering av klisterdekalerna.
- ☞ Suositellaan siirtokuvien siirtämiseen.
- ☞ Рекомендується для нанесення переводних картинок.
- ☞ Zalecane do przyklejenia kalkomanii.
- ☞ Doporučujeme k umístění obtiskovacích obrázků.
- ☞ A matrica felhelyezéséhez ajánlható.
- ☞ Odporúča sa pre umiestnenie obtlačkového obrázku.
- ☞ Recomandat pentru aplicarea abtîbildurilor.
- ☞ Препоръчва се за поставяне на ваденки.
- ☞ Pri nameščanju nalepnic priporočamo.
- ☞ Συνιστάται για την τοποθέτηση των χαλκομανιών.
- ☞ Çikartmaların takılması için önerilir.



\*

- ☞ Zur Anbringung der Klarteile empfohlen.
- ☞ Recommended to fix clear parts.
- ☞ Recommandé pour fixer les pièces transparentes.
- ☞ Aanbevolen voor het aanbrengen van transparante delen.
- ☞ Raccomandato per l'applicazione delle parti trasparenti.
- ☞ Recomendado para fijar las piezas transparentes.
- ☞ Recomendado para a aplicação das peças transparentes.
- ☞ Anbefales til anbringelse af de klare dele.
- ☞ Anbefales til å feste klare deler.
- ☞ Rekommenderad för montering av de genomskinliga detaljerna.
- ☞ Suositellaan läpinäkyvien osien siirtämiseen.
- ☞ Рекомендується для крепления прозрачных деталей.
- ☞ Zalecane do przyklejenia przezroczystych części.
- ☞ Doporučujeme k umístění průhledných dílů.
- ☞ Az átlátszó darabok felhelyezéséhez ajánlható.
- ☞ Odporúča sa pre umiestnenie čírych dielov.
- ☞ Recomandat pentru aplicarea pieselor transparente.
- ☞ Препоръчва се за поставяне на прозрачни части.
- ☞ Pri nameščanju prozornih delov priporočamo.
- ☞ Συνιστάται για την τοποθέτηση των διάφανων μερών.
- ☞ Şeffaf parçaların takılması için önerilir.

\*

- ☞ Nicht enthalten
- ☞ Not included
- ☞ Non fourni
- ☞ Behoort niet
- ☞ Non incluso
- ☞ No incluido
- ☞ Não incluído
- ☞ Medfølger ik
- ☞ Ikke inkludert
- ☞ Ingår ej
- ☞ Ei sisalla
- ☞ Не съдържа
- ☞ Nie wchodzi
- ☞ Neni obsažen
- ☞ Nem tartalm
- ☞ Neobsahuje
- ☞ Nu este incl
- ☞ Не се вклю
- ☞ Ni priloženo
- ☞ Δεν περιλαμ
- ☞ İçermiyor

# Benötigte Farben / Required colours

- FR Peintures nécessaires
- NL Benodigde kleuren
- IT Colori necessari
- ES Colores necesarios
- PT Cores necessárias
- DK Nødvendige farver
- NO Nødvendige farger
- SE Erforderliga farger
- F Tarvittavat värit
- RU Необходимые краски
- PL Potrzebne kolory
- CZ Potřebné barvy
- HU Szükséges színek
- SK Požadované farby
- RO Colori necesare
- BG Необходими цветове
- SI Potrebne barve
- GR Απαιτούμενα χρώματα
- TR Gerekl renkler



- DE Beispiel: mischen
- GB Example: mixing
- FR Exemple: mélanger
- NL Voorbeeld: mengen
- IT Esempio: mescolare
- ES Ejemplo: mezclar
- PT Exemplo: misturar
- DK Eksempel: blanding
- NO Eksempel: blanding
- SE Exempel: blanda
- F Esimerkki: sekoittaminen
- RU Пример: смешивание
- PL Przykład: mieszac
- CZ Příklad: míchání
- HU Példa: keverés
- SK Příklad: miešanie
- NO Exempler: amestecare
- BG Пример: смесване
- SI Primer: mešanje
- GR Παράδειγμα: αναμείξη
- TR Örnek: karıştırma

60% 57 A 05 40%

- DE Grau matt
- GB Grey matt
- FR Gris mat
- NL Grijs mat
- IT Grigio opaco
- ES Gris mate
- PT Cinzento mate
- DK Grå mat
- NO Grå matt
- SE Grå matt
- F Harmaa matta
- RU Жёлтый матовый
- PL Szary matowy
- CZ Sedá matný
- HU Szürke, fénytelen
- SK Sivá matný
- NO Gri mat
- BG Сиво матово
- SI Siva mat
- GR Γκρι ματ
- TR Gri mat
- +
- DE Weiß matt
- GB White matt
- FR Blanc mat
- NL Wit mat
- IT Bianco opaco
- ES Blanco mate
- PT Branco mate
- DK Hvid mat
- NO Hvit matt
- SE Vit matt
- F Valkoinen matta
- RU Белый матовый
- PL Biały matowy
- CZ Bílá matný
- HU Fehér, fénytelen
- SK Biela matný
- NO Alb mat
- BG Бяло матово
- SI Bela mat
- GR Ασπρο ματ
- TR Beyaz mat

09

B

- DE Anthrazit matt
- GB Anthracite matt
- FR Anthracite mat
- NL Antraciet mat
- IT Antracite opaco
- ES Antracita mate
- PT Antracite mate
- DK Antracitgrå mat
- NO Antrasitt matt
- SE Antracitgrå matt
- F Antrasiitinharmaa matta
- RU Антрацит матовый
- PL Antracyt matowy
- CZ Antracitová šedá matný
- HU Antracit, fénytelen
- SK Čierna uhľová matný
- RO Antracit mat
- BG Антрацит матово
- SI Antracit mat
- GR Γκρι ανθρακι ματ
- TR Anthrazit mat

05

C

- DE Weiß matt
- GB White matt
- FR Blanc mat
- NL Wit mat
- IT Bianco opaco
- ES Blanco mate
- PT Branco mate
- DK Hvid mat
- NO Hvit matt
- SE Vit matt
- F Valkoinen matta
- RU Белый матовый
- PL Biały matowy
- CZ Bílá matný
- HU Fehér, fénytelen
- SK Biela matný
- RO Alb mat
- BG Бяло матово
- SI Bela mat
- GR Ασπρο ματ
- TR Beyaz mat

65

D

- DE Bronzegrün matt
- GB Bronze green matt
- FR Vert bronze mat
- NL Bronsgroen mat
- IT Verde bronzo opaco
- ES Verde bronce mate
- PT Verde bronze mate
- DK Bronzegrøn mat
- NO Bronsegrønn matt
- SE Bronsgrøn matt
- F Pronssinvihreä matta
- RU Бронзово-зелёный матовый
- PL Brązowozielony matowy
- CZ Bronzová zelená matný
- HU Bronz zöld, fénytelen
- SK Bronzovo zelená matný
- RO Verde-bronz mat
- BG Бронзовозелено матово
- SI Bronasto-zelena mat
- GR Λαδί ματ
- TR Bakır yeşili mat

15

E

- DE Gelb matt
- GB Yellow matt
- FR Jaune mat
- NL Geel mat
- IT Giallo opaco
- ES Amarillo mate
- PT Amarelo mate
- DK Gul mat
- NO Gul matt
- SE Gul matt
- F Keltainen matta
- RU Жёлтый матовый
- PL Żółty matowy
- CZ Žlutá matný
- HU Sárga, fénytelen
- SK Žltá matný
- RO Galben mat
- BG Жълто матово
- SI Rumena mat
- GR Κίτρινο ματ
- TR Sarı mat

99

F

- DE Aluminium metallic
- GB Aluminium metallic
- FR Aluminium métallique
- NL Aluminium metallic
- IT Alluminio metallico
- ES Aluminio metálico
- PT Alumínio metálico
- DK Aluminium metallisk
- NO Aluminium metallic
- SE Aluminium metallic
- F Alumiini metallinen
- RU Алюминий металлический
- PL Aluminium metaliczny
- CZ Hliníková metalizovaný
- HU Alumínium metál
- SK Hliníková metaliza
- RO Aluminiiu metalic
- BG Алюминий металик
- SI Aluminijasta kovinska
- GR Αλουμίνιο μεταλλικό
- TR Alüminyum grisi metalik

91

G

- DE Eisen metallic
- GB Iron metallic
- FR Fer métallique
- NL IJzer metallic
- IT Ferro metallico
- ES Acero metálico
- PT Aço metálico
- DK Stål metallisk
- NO Jern metallic
- SE Stål metallic
- F Teräs metallinen
- RU Сталь металлический
- PL Grafyt metaliczny
- CZ Ocelová metalizovaný
- HU Acélmetál
- SK Ocelová metaliza
- RO Fier metalic
- BG Желязо металик
- SI Železna kovinska
- GR Χρώμα σιδήρου μεταλλικό
- TR Metalik metalik

77

H

- DE Staubgrau matt
- GB Dusty grey matt
- FR Gris poussière mat
- NL Stofgrijs mat
- IT Grigio polvere opaco
- ES Gris polvo mate
- PT Cinza pó mate
- DK Støvet grå mat
- NO Støvgrå matt
- SE Damingrå matt
- F Tomunharmaa matta
- RU Серая пыль матовый
- PL Szary stalowy matowy
- CZ Prachová šed matný
- HU Porszürke, fénytelen
- SK Prachovo sivá matný
- RO Gri prafulit mat
- BG Прашиносиво матово
- SI Prašno-siva mat
- GR Σαχτί ματ
- TR Duman grisi mat

88

I

- DE Ocker matt
- GB Ochre matt
- FR Ocre mat
- NL Oker mat
- IT Ocra opaco
- ES Ocre mate
- PT Ocre mate
- DK Okkerbrun mat
- NO Okerbrun matt
- SE Ockrabrun matt
- F Okranruskea matta
- RU Охра матовый
- PL Ochra matowy
- CZ Okr hnědý matný
- HU Okker, fénytelen
- SK Okrová matný
- RO Ocru mat
- BG Охра матово
- SI Oker mat
- GR Όχρα ματ
- TR Toprak rengi mat

302

J

- DE Schwarz seidenmatt
- GB Black silk matt
- FR Noir satiné mat
- NL Zwart zijdemat
- IT Nero opaco satinato
- ES Negro mate sedoso
- PT Preto mate sedoso
- DK Sort silkematt
- NO Sort silkematt
- SE Svart sidenmatt
- F Musta silkkimatta
- RU Чёрный шелковисто-матовый
- PL Czarny jedwabiscie matowy
- CZ Černá jemně matný
- HU Fekete, fakóselymes
- SK Čierna hodvábné matný
- RO Negru satinat
- BG Черно коприненоматово
- SI Črna svileno-mat
- GR Μαύρο σατινέ
- TR Siyah ipeksi mat

731

K

- DE Rot klar
- GB Red clear
- FR Rouge clair
- NL Rood helder
- IT Rosso chiaro
- ES Rojo claro
- PT Vermelho transparente
- DK Rodbrun klar
- NO Rod klar
- SE Rodbrun klar
- F Punainen kirkas
- RU Красный прозрачный
- PL Czerwony przezroczysty
- CZ Červená bezbarvý
- HU Piros, világos
- SK Červená číry
- RO Roșu curat
- BG Червено бистро
- SI Rdeča čista
- GR Κόκκινο διάφανο
- TR Kırmızı canlı

90% 01 **L** 48 10%

<ul style="list-style-type: none"> <li>DE Farblös glänzend</li> <li>GB Clear gloss</li> <li>FR Incoloro brillant</li> <li>NL Kleurloos glanzend</li> <li>IT Incoloro lucido</li> <li>ES Incoloro brillante</li> <li>PT Verniz brilhante</li> <li>DK Klarlak blank</li> <li>NO Klar glansende</li> <li>SE Klarlack blank</li> <li>F Variton kiiltävä</li> <li>RU Морская волна матовый</li> <li>PL Przejroczyście błyszcząca</li> <li>CZ Bezbarvá lesklý</li> <li>HU Szintelen, fényes</li> <li>SK Priehľadný lesklý</li> <li>RO Transparent strălucitor</li> <li>BG Безцветно глянцово</li> <li>S Brezbarvna sijoča</li> <li>GR Διαφανο υαλαστέρο</li> <li>TR Rensiz parlak</li> </ul>	+	<ul style="list-style-type: none"> <li>DE Seegrün matt</li> <li>GB Sea green matt</li> <li>FR Vert mer mat</li> <li>NL Zeegroen mat</li> <li>IT Verde mare opaco</li> <li>ES Verde mar mate</li> <li>PT Verde mar mate</li> <li>DK Havgrøn mat</li> <li>NO Sjøgrønn matt</li> <li>SE Havsgrön matt</li> <li>F Merenvihreä matta</li> <li>RU Морская волна матовый</li> <li>PL Morska zieleń matowy</li> <li>CZ Mořská zelená matný</li> <li>HU Tengerzöld, fénytelen</li> <li>SK Morská zelená matný</li> <li>RO Verde-marin mat</li> <li>BG Морскозелено матово</li> <li>S Jezersko-zelena mat</li> <li>GR Πράσινο βαθύ ματ</li> <li>TR Deniz yeşili mat</li> </ul>
--	---	--

70% 05 **N** 57 30%

<ul style="list-style-type: none"> <li>DE Weiß matt</li> <li>GB White matt</li> <li>FR Blanc mat</li> <li>NL Wit mat</li> <li>IT Bianco opaco</li> <li>ES Blanco mate</li> <li>PT Branco mate</li> <li>DK Hvid mat</li> <li>NO Hvit matt</li> <li>SE Vit matt</li> <li>F Valkoinen matta</li> <li>RU Белый матовый</li> <li>PL Biały matowy</li> <li>CZ Bílá matný</li> <li>HU Fehér, fénytelen</li> <li>SK Biela matný</li> <li>RO Alb mat</li> <li>BG Бяло матово</li> <li>S Bela mat</li> <li>GR Άσπρο ματ</li> <li>TR Beyaz mat</li> </ul>	+	<ul style="list-style-type: none"> <li>DE Grau matt</li> <li>GB Grey matt</li> <li>FR Gris mat</li> <li>NL Grijs mat</li> <li>IT Grigio opaco</li> <li>ES Gris mate</li> <li>PT Cinzento mate</li> <li>DK Grå mat</li> <li>NO Grå matt</li> <li>SE Grå matt</li> <li>F Harmaa matta</li> <li>RU Серый матовый</li> <li>PL Szary matowy</li> <li>CZ Šedá matný</li> <li>HU Szürke, fénytelen</li> <li>SK Sivá matný</li> <li>RO Gri mat</li> <li>BG Сиво матово</li> <li>S Siva mat</li> <li>GR Γκρι ματ</li> <li>TR Gri mat</li> </ul>	<ul style="list-style-type: none"> <li>DE Grau</li> <li>GB Grey</li> <li>FR Gris r</li> <li>NL Grijs</li> <li>IT Grigio</li> <li>ES Gris r</li> <li>PT Cinze</li> <li>DK Grå r</li> <li>NO Grå r</li> <li>SE Grå r</li> <li>F Harr</li> <li>RU Серь</li> <li>PL Szary</li> <li>CZ Šedá</li> <li>HU Szürk</li> <li>SK Sivá</li> <li>RO Gri n</li> <li>BG Сивс</li> <li>S Siva</li> <li>GR Γκρι r</li> <li>TR Gri r</li> </ul>
--	---	--	--

60% 65 20% 05 **P** 15 20%

<ul style="list-style-type: none"> <li>DE Bronzegrün matt</li> <li>GB Bronze green matt</li> <li>FR Vert bronze mat</li> <li>NL Bronsgroen mat</li> <li>IT Verde bronzo opaco</li> <li>ES Verde bronce mate</li> <li>PT Verde bronze mate</li> <li>DK Bronzegrøn mat</li> <li>NO Bronsegrønn matt</li> <li>SE Bronsgrön matt</li> <li>F Pronssinvihreä matta</li> <li>RU Бронзово-зеленый матовый</li> <li>PL Brązowozielony matowy</li> <li>CZ Bronzová zelená matný</li> <li>HU Bronz zöld, fénytelen</li> <li>SK Bronzovo zelená matný</li> <li>RO Verde-bronz mat</li> <li>BG Бронзовозелено матово</li> <li>S Bronzasto-zelena mat</li> <li>GR Λαδί ματ</li> <li>TR Bakır yeşili mat</li> </ul>	+	<ul style="list-style-type: none"> <li>DE Weiß matt</li> <li>GB White matt</li> <li>FR Blanc mat</li> <li>NL Wit mat</li> <li>IT Bianco opaco</li> <li>ES Blanco mate</li> <li>PT Branco mate</li> <li>DK Hvid mat</li> <li>NO Hvit matt</li> <li>SE Vit matt</li> <li>F Valkoinen matta</li> <li>RU Белый матовый</li> <li>PL Biały matowy</li> <li>CZ Bílá matný</li> <li>HU Fehér, fénytelen</li> <li>SK Biela matný</li> <li>RO Alb mat</li> <li>BG Бяло матово</li> <li>S Bela mat</li> <li>GR Άσπρο ματ</li> <li>TR Beyaz mat</li> </ul>	<ul style="list-style-type: none"> <li>DE Gelb matt</li> <li>GB Yellow matt</li> <li>FR Jaune mat</li> <li>NL Geel mat</li> <li>IT Giallo opaco</li> <li>ES Amarillo mate</li> <li>PT Amarelo mate</li> <li>DK Gul mat</li> <li>NO Gul matt</li> <li>SE Gul matt</li> <li>F Keltainen matta</li> <li>RU Желтый матовый</li> <li>PL Żółty matowy</li> <li>CZ Žlutá matný</li> <li>HU Sárga, fénytelen</li> <li>SK Žltá matný</li> <li>RO Galben mat</li> <li>BG Жълто матово</li> <li>S Rumena mat</li> <li>GR Κίτρινο ματ</li> <li>TR Sarı mat</li> </ul>
--	---	--	---

60% 67 10% 69 **Q** 15

<ul style="list-style-type: none"> <li>DE Grüngrau matt</li> <li>GB Greenish grey matt</li> <li>FR Gris vert mat</li> <li>NL Groengrijs mat</li> <li>IT Grigio verdastro opaco</li> <li>ES Gris verdoso mate</li> <li>PT Cinza esverdeado mate</li> <li>DK Grøngrå mat</li> <li>NO Grønngrå matt</li> <li>SE Gröngrå matt</li> <li>F Vihreänharmaa matta</li> <li>RU Серо-зеленый матовый</li> <li>PL Zielonoszary matowy</li> <li>CZ Zelenošedá matný</li> <li>HU Zöldesszürke, fénytelen</li> <li>SK Zelenosivá matný</li> <li>RO Gri verzui mat</li> <li>BG Зеленикавосиво матово</li> <li>S Zeleno-siva mat</li> <li>GR Γκριζοπράσινο ματ</li> <li>TR Gri yeşil mat</li> </ul>	+	<ul style="list-style-type: none"> <li>DE Granitgrau matt</li> <li>GB Granite grey matt</li> <li>FR Gris granit mat</li> <li>NL Granietgrijs mat</li> <li>IT Grigio granito opaco</li> <li>ES Gris granito mate</li> <li>PT Cinza granito mate</li> <li>DK Granitgrå mat</li> <li>NO Granittgrå matt</li> <li>SE Granitgrå matt</li> <li>F Granitinharmaa matta</li> <li>RU Серый гранит матовый</li> <li>PL Granitowoszary matowy</li> <li>CZ Žulová šedá matný</li> <li>HU Gránitszürke, fénytelen</li> <li>SK Žulovo sivá matný</li> <li>RO Gri-granit mat</li> <li>BG Гранитносиво матово</li> <li>S Granitno-siva mat</li> <li>GR Μολυβί ματ</li> <li>TR Granit grisi mat</li> </ul>	<ul style="list-style-type: none"> <li>DE Gell</li> <li>GB Yell</li> <li>FR Jaur</li> <li>NL Gee</li> <li>IT Gia</li> <li>ES Am</li> <li>PT Am</li> <li>DK Gul</li> <li>NO Gul</li> <li>SE Gul</li> <li>F Kel</li> <li>RU Жѐ</li> <li>PL Żół</li> <li>CZ Žlu</li> <li>HU Sár</li> <li>SK Žlt</li> <li>NO Gal</li> <li>BG Жѐ</li> <li>S Ru</li> <li>GR Kit</li> <li>TR Sai</li> </ul>
--	---	---	--

36

**R**

- DE Karminrot matt
- GB Carmine red matt
- FR Rouge carmin mat
- NL Karmijnrood mat
- IT Rosso carminio opaco
- ES Rojo carmin mate
- PT Vermelho carmin mate
- DK Karminrød mat
- NO Karminrød matt
- SE Karminröd matt
- F Karmininpunainen matta
- RU Карминный матовый
- PL Karminowa czerwień matowy
- CZ Karminová červená matný
- HU Karminpiros, fénytelen
- SK Karminovo červená matný
- RO Roșu-carmin mat
- BG Карминовочервено матово
- S Karminsko-rdeča mat
- GR Άλικο κόκκινο ματ
- TR Karmen kırmizisi mat

66

**S**

- DE Olivgrau matt
- GB Olive grey matt
- FR Gris olive mat
- NL Olijfgrijs mat
- IT Grigio oliva opaco
- ES Gris oliva mate
- PT Cinza azeitona mate
- DK Olivengrå mat
- NO Olivengrå matt
- SE Olivgrå matt
- F Oliivinharmaa matta
- RU Оливково-серый матовый
- PL Oliwkowoszary matowy
- CZ Olivová šedá matný
- HU Olajszürke, fénytelen
- SK Olivovo sivá matný
- RO Gri măsliniu mat
- BG Маслиненосиво матово
- S Olivno-siva mat
- GR Γκρι-λαδί ματ
- TR Zeytin yeşili mat

89

**T**

- DE Beige matt
- GB Beige matt
- FR Beige mat
- NL Beige mat
- IT Beige opaco
- ES Beige mate
- PT Beige mate
- DK Beige mat
- NO Beige matt
- SE Beige matt
- F Beige matta
- RU Бежевый матовый
- PL Beżowy matowy
- CZ Běžová matný
- HU Bézs, fénytelen
- SK Běžová matný
- RO Bej mat
- BG Бежово матово
- S Bež mat
- GR Μπεζ ματ
- TR Bej mat

60%

91

U

87

40%

DE Eisen metallic  
 GB Iron metallic  
 FR Fer métallique  
 NL IJzer metallic  
 IT Ferro metallico  
 ES Acero metálico  
 PT Aço metálico  
 DK Stål metallisk  
 NO Jern metallic  
 SE Stål metallic  
 FI Teräs metallinen  
 RU Сталь металл  
 PL Grafit metaliczny  
 CZ Ocelová metalizová  
 HU Acélmetál  
 SK Ocelová metaliza  
 RO Fier metallic  
 BG Желязо металик  
 SI Železna kovinska  
 GR Χρώμα σιδήρου μεταλλικό  
 TR Metalik metalik

+

DE Erdfarbe matt  
 GB Earth matt  
 FR Couleur terre mat  
 NL Aardkleur mat  
 IT Color terra opaco  
 ES Marrón tierra mate  
 PT Castanho terra mate  
 DK Jordfarve mat  
 NO Jordbrun matt  
 SE Jordfarg matt  
 FI Maanruskea matta  
 RU Земельный матовый  
 PL Ziemisty matowy  
 CZ Zemitě hnědá matný  
 HU Földszínű, fénytelen  
 SK Zemito hnědá matný  
 RO Maro pământiu mat  
 BG Земнокафяво матово  
 SI Zemeljska-barva mat  
 GR Καφέ γήινο ματ  
 TR Toprak kahvesi mat

90

V

DE Silber metallic  
 GB Silver metallic  
 FR Argent métallique  
 NL Zilver metallic  
 IT Argento metallico  
 ES Plata metálico  
 PT Prata metálico  
 DK Sølv metallisk  
 NO Sølv metallic  
 SE Silver metallic  
 FI Hopea metallinen  
 RU Серебрянный металл  
 PL Srebrny metaliczny  
 CZ Stříbrná metalizová  
 HU Ezüstmetál  
 SK Strieborná metaliza  
 RO Argintiu metallic  
 BG Сребро металик  
 SI Srebrna kovinska  
 GR Ασήρι μεταλλικό  
 TR Gümüş rengi metalik

90%

06

X

57

10%

DE Teerschwartz matt  
 GB Tar black matt  
 FR Noir goudron mat  
 NL Teerzwart mat  
 IT Nero catrame opaco  
 ES Negro breá mate  
 PT Preto alcatrão mate  
 DK Tjæresort mat  
 NO Tjæresort matt  
 SE Tjärsvart matt  
 FI Tervanmusta matta  
 RU Битумно-чёрный матовый  
 PL Czarna smoła matowy  
 CZ Dehtová černá matný  
 HU Kátrányfekete, fénytelen  
 SK Čierna térová matný  
 RO Negru-inchis mat  
 BG Катранено черно матово  
 SI Katransko-črna mat  
 GR Μαύρο βαθύ ματ  
 TR Katran siyahı mat

+

DE Grau matt  
 GB Grey matt  
 FR Gris mat  
 NL Grijs mat  
 IT Grigio opaco  
 ES Gris mate  
 PT Cinzento mate  
 DK Grå mat  
 NO Grå matt  
 SE Grå matt  
 FI Harmaa matta  
 RU Серый матовый  
 PL Szary matowy  
 CZ Seda matný  
 HU Szürke, fénytelen  
 SK Sivá matný  
 RO Gri mat  
 BG Сиво матово  
 SI Siva mat  
 GR Γκρι ματ  
 TR Gri mat

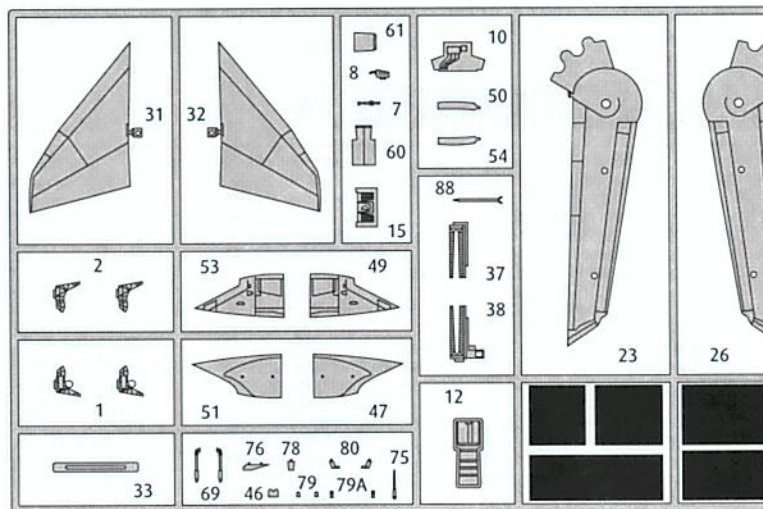
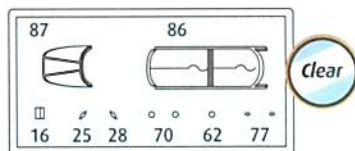
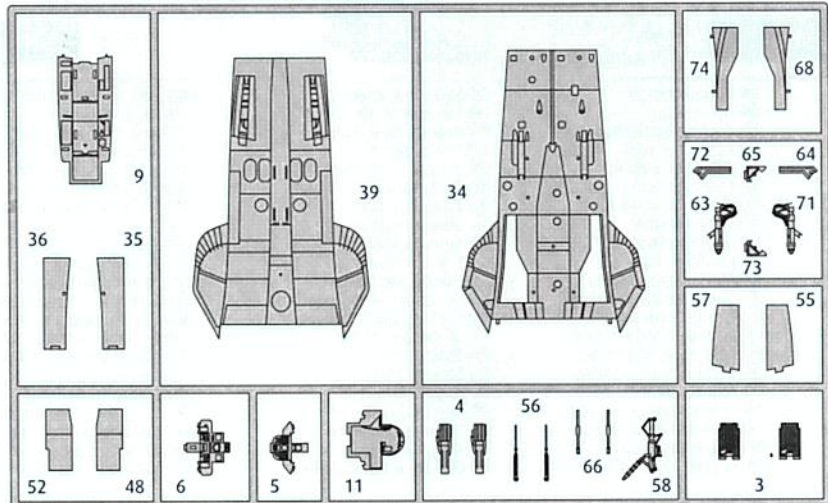

DE Nicht benötigte Teile  
 GB Parts not used.  
 FR Pièces non utilisées.  
 NL Niet benodigde onderdelen.  
 IT Parti non necessarie.  
 ES Piezas no utilizadas.  
 PT Peças não utilizadas.

DK Dele der ikke skal bruges.  
 NO Deler som ikke er nødvendige.  
 SE Ej nödvändiga delar.  
 FI Tarpeettomat osat.  
 RU Неиспользуемые детали.  
 PL Niepotrzebne części.  
 CZ Nepotřebné díly.

HU Szükségtelen alkatrészek.  
 SK Nepotrebné diely.  
 NO Piese care nu sunt necesare.  
 BG Ненужни детайли.  
 SI Nepotrebni deli.  
 GR Μη χρησιμοποιούμενα μέρη.  
 TR Gerekli olmayan parçalar.

DE Kundenservice: [www.revell-service.de](http://www.revell-service.de)  
 GB Customer Service: [www.revell-service.de](http://www.revell-service.de)  
 US Customer Service: [www.revell-service.de](http://www.revell-service.de)  
 FR Service clientèle: [www.revell-service.de](http://www.revell-service.de)  
 NL Klantenservice: [www.revell-service.de](http://www.revell-service.de)  
 ES Servicio al cliente: [www.revell-service.de](http://www.revell-service.de)  
 IT Servizio clienti: [www.revell-service.de](http://www.revell-service.de)  
 PT Serviço de apoio ao cliente: [www.revell-service.de](http://www.revell-service.de)  
 DK Kundeservice: [www.revell-service.de](http://www.revell-service.de)  
 NO Kundeservice: [www.revell-service.de](http://www.revell-service.de)  
 SE Kundtjänst: [www.revell-service.de](http://www.revell-service.de)

FI Asiakaspalvelu: [www.revell-service.de](http://www.revell-service.de)  
 RU Служба поддержки клиентов: [www.revell-service.de](http://www.revell-service.de)  
 PL Dział obsługi klienta: [www.revell-service.de](http://www.revell-service.de)  
 CZ Zákaznický servis: [www.revell-service.de](http://www.revell-service.de)  
 HU Ügyfélszolgálat: [www.revell-service.de](http://www.revell-service.de)  
 SK Zákaznický servis: [www.revell-service.de](http://www.revell-service.de)  
 RO Serviciul clienți [www.revell-service.de](http://www.revell-service.de)  
 BG Отдел за обслужване на клиенти: [www.revell-service.de](http://www.revell-service.de)  
 SI Služba za pomoč strankam: [www.revell-service.de](http://www.revell-service.de)  
 GR Τμήμα εξυπηρέτησης πελατών: [www.revell-service.de](http://www.revell-service.de)  
 TR Müşteri hizmetleri: [www.revell-service.de](http://www.revell-service.de)

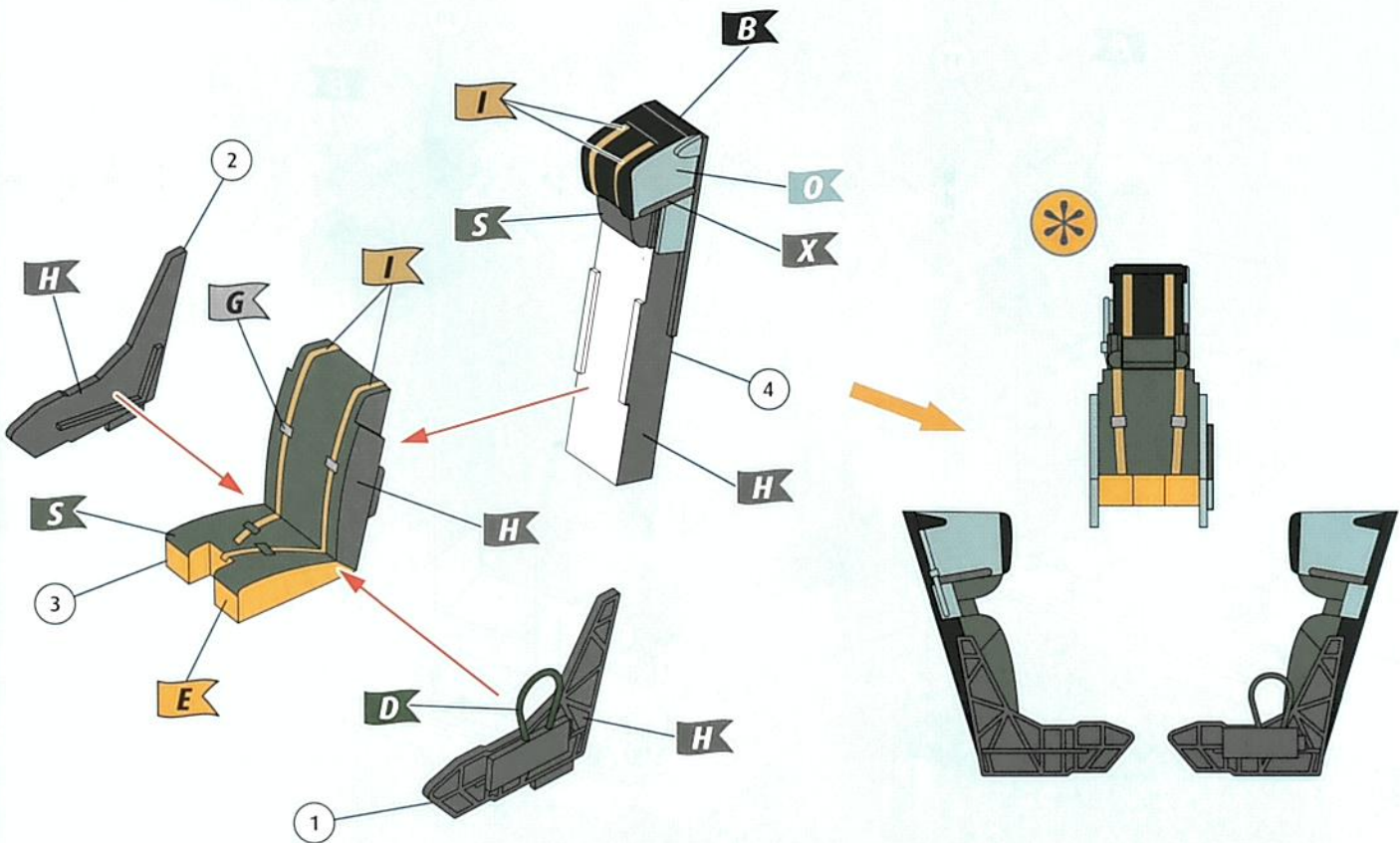
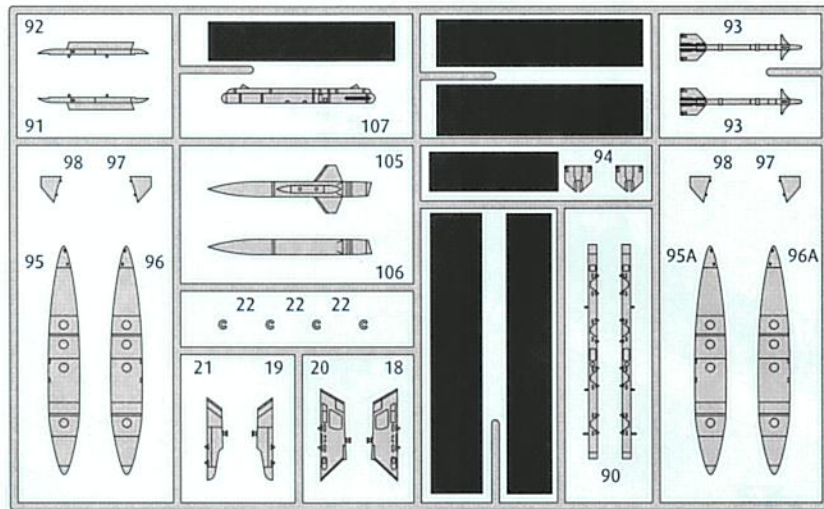
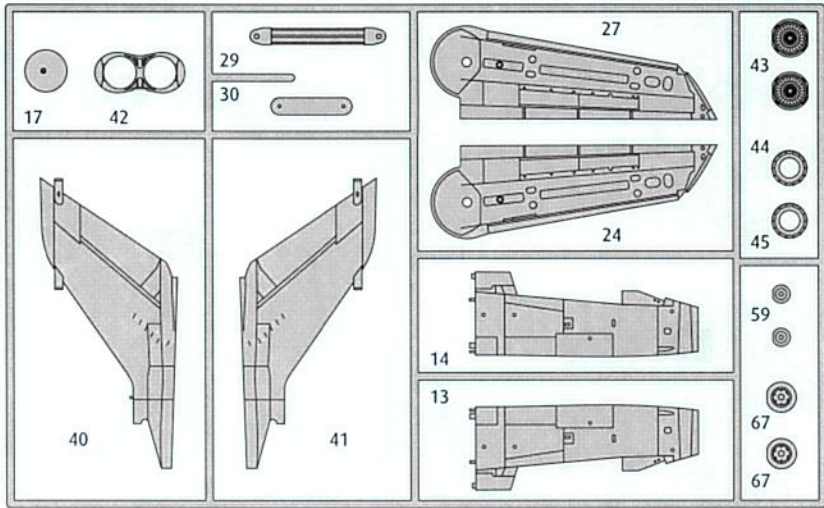

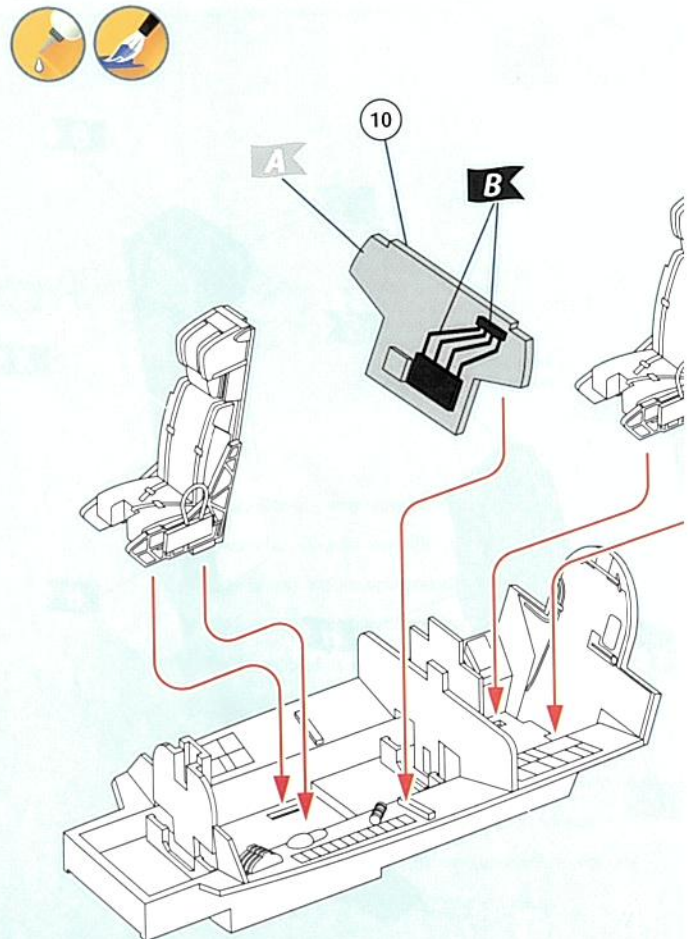
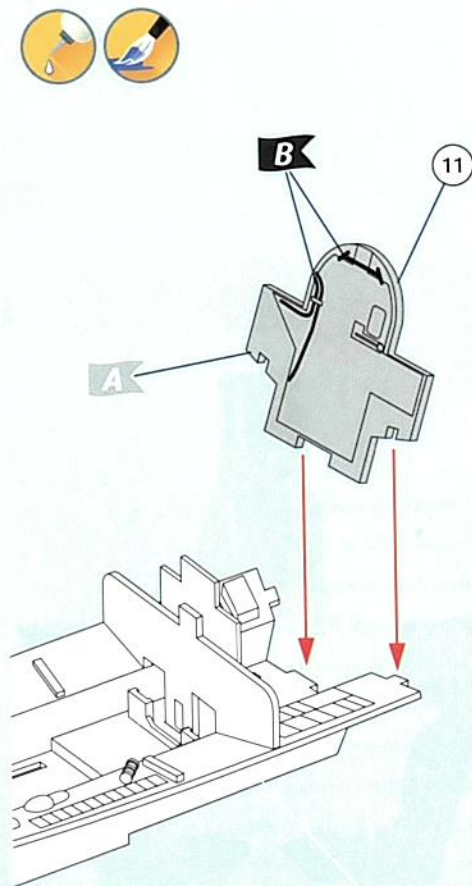
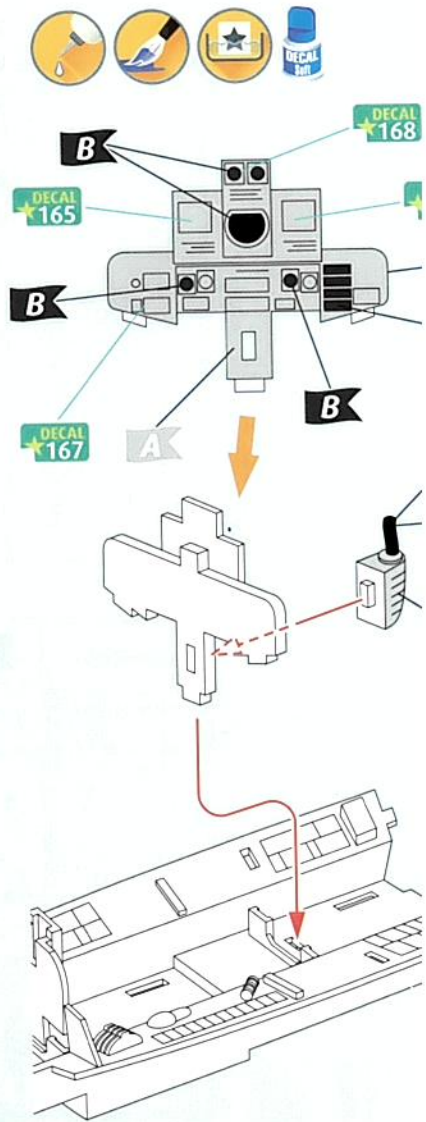
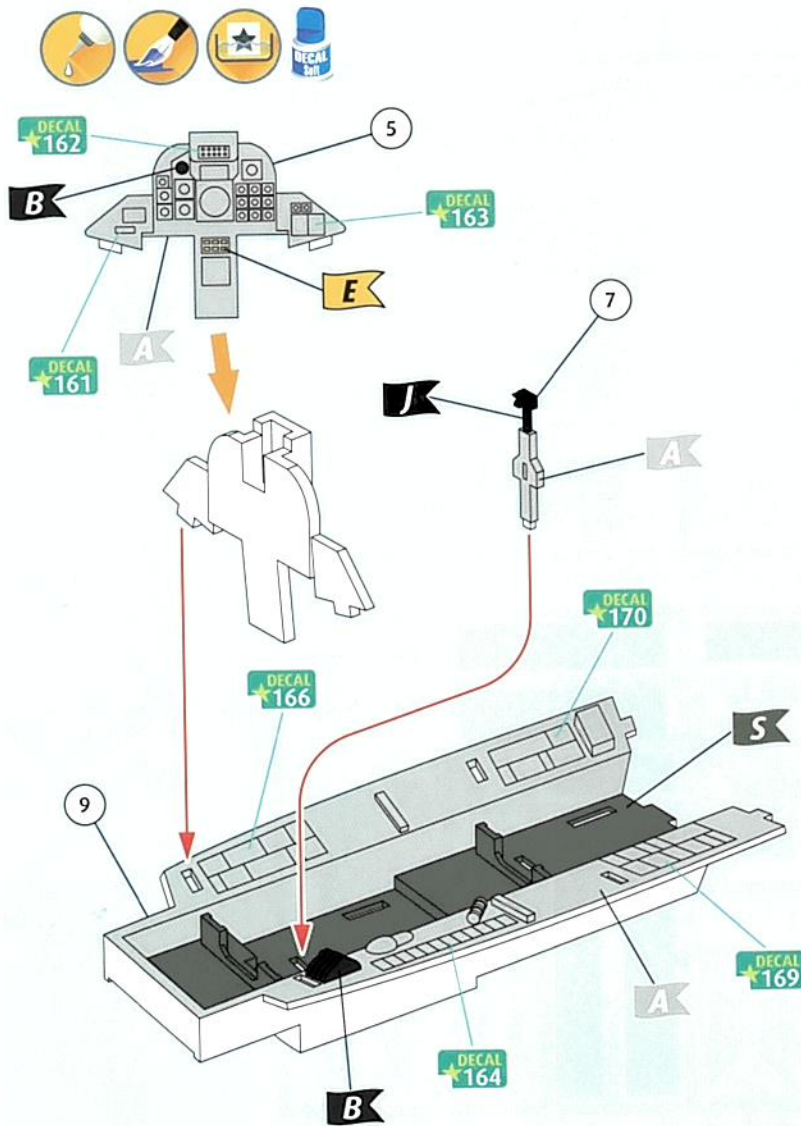

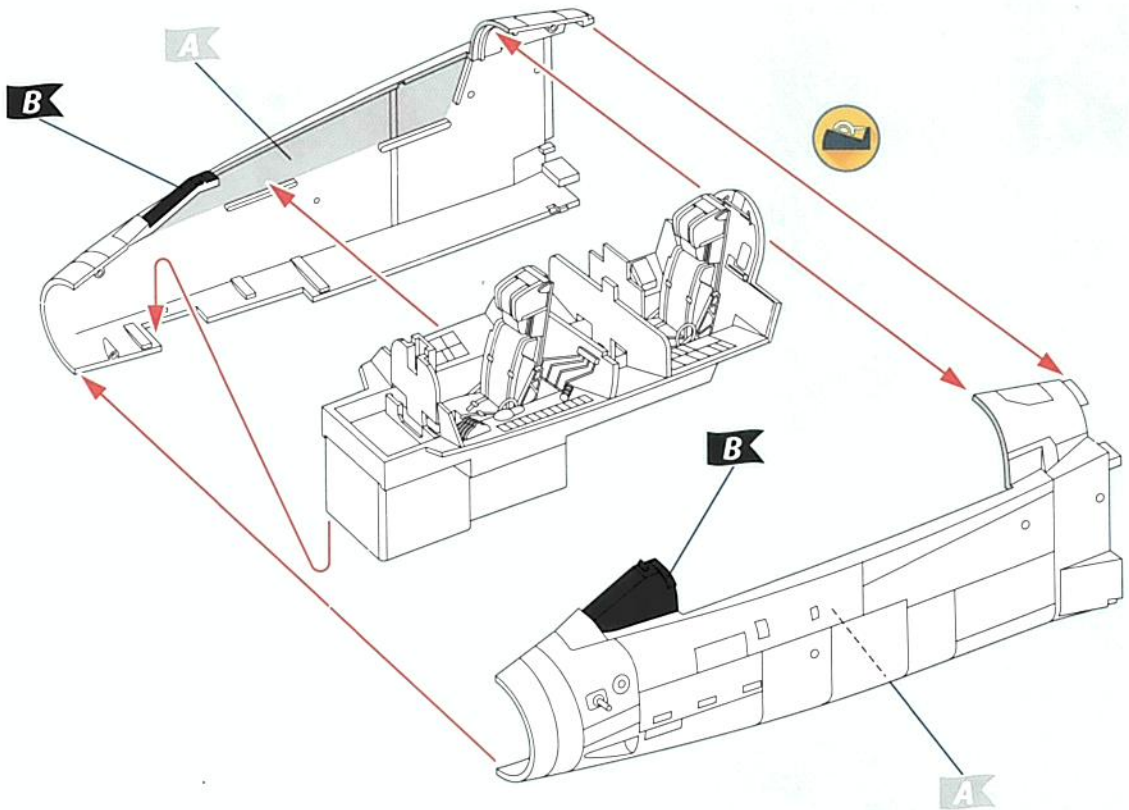
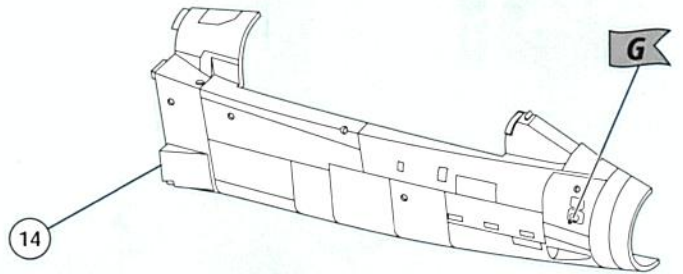
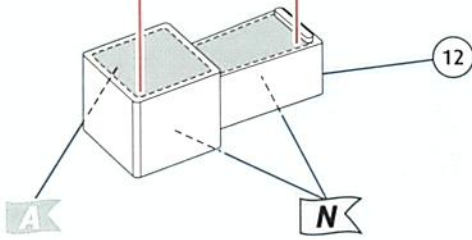
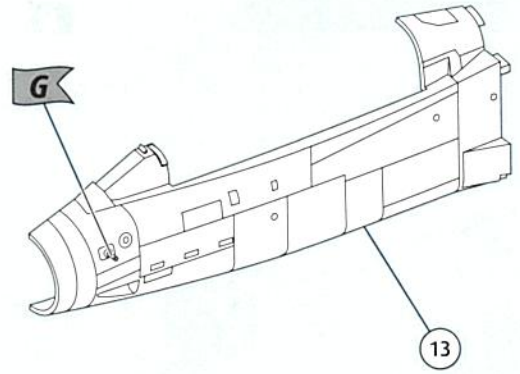
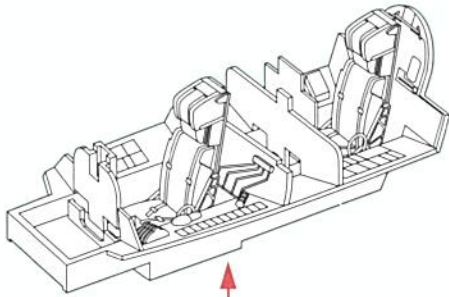

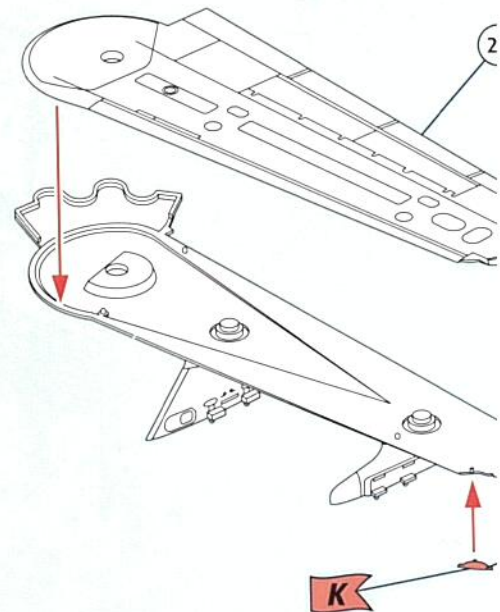
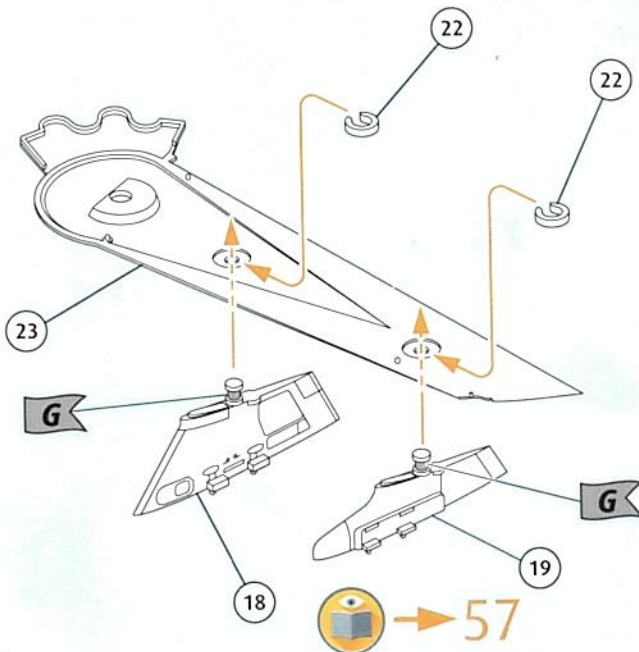
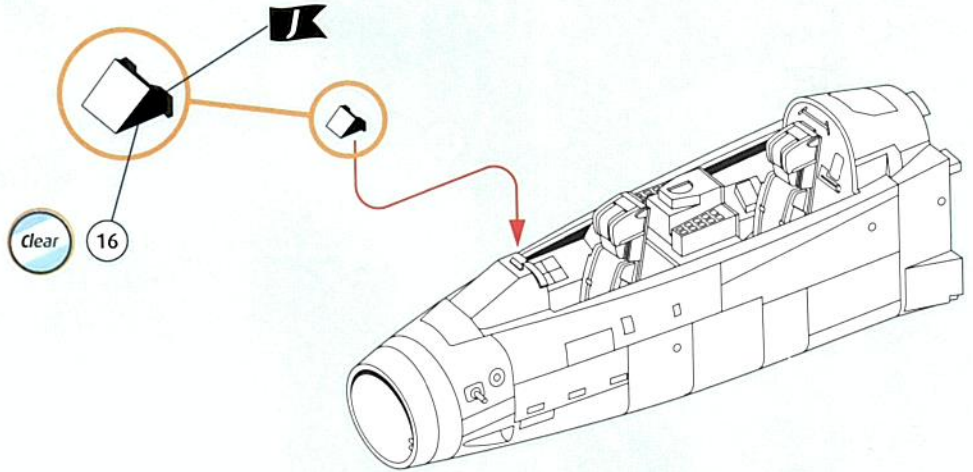
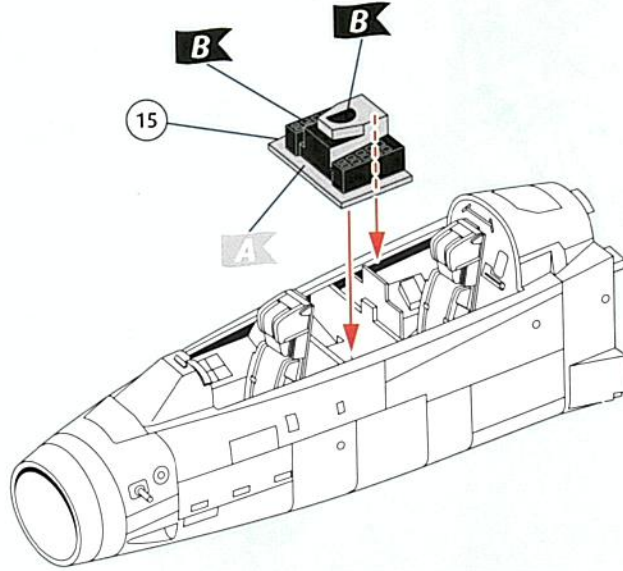

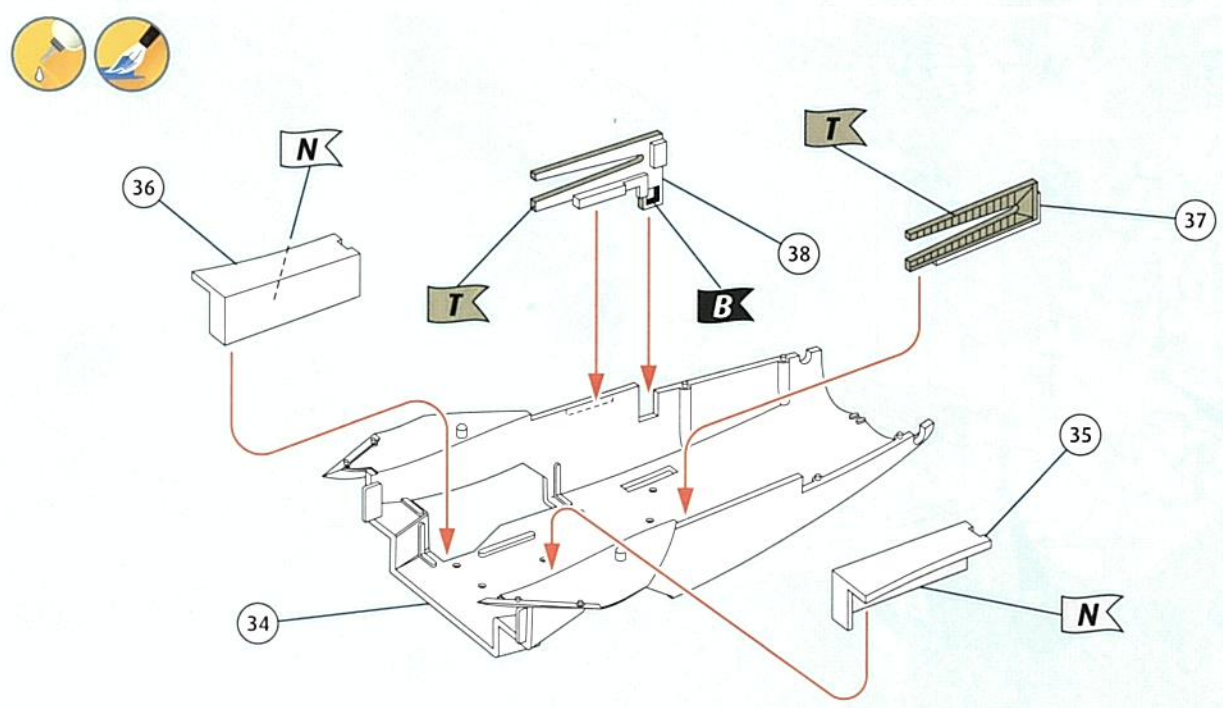
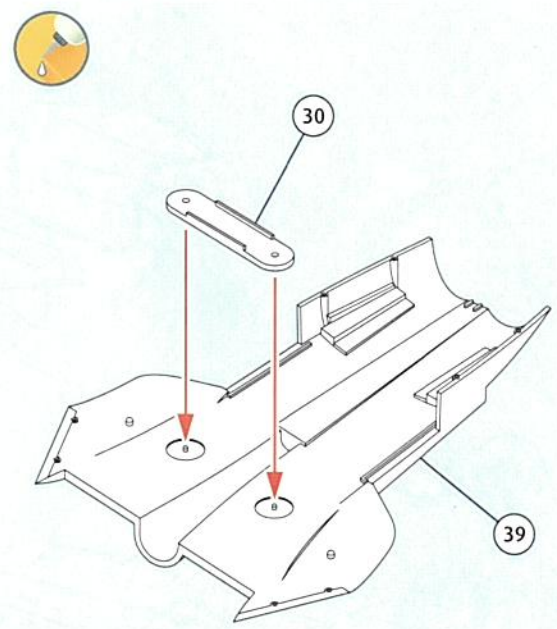
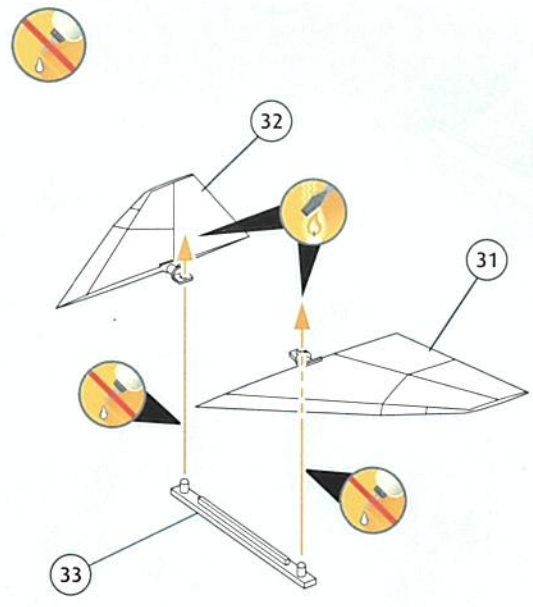
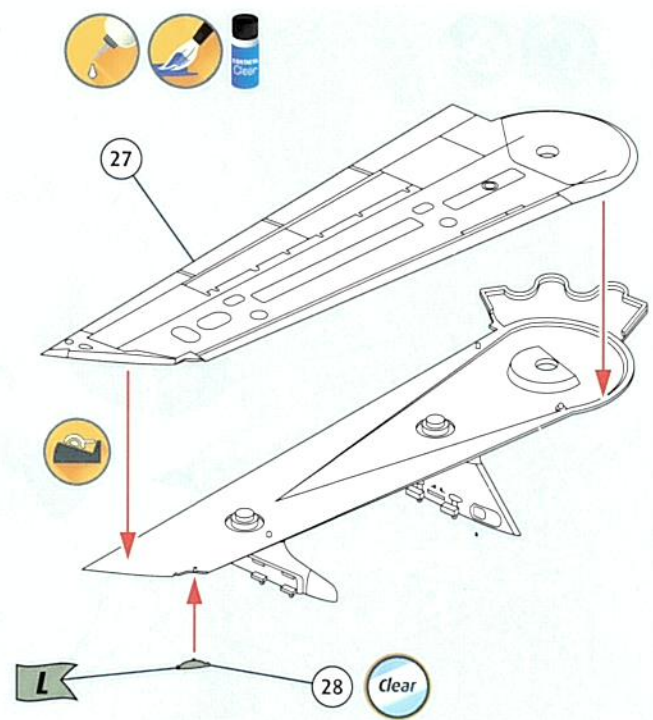
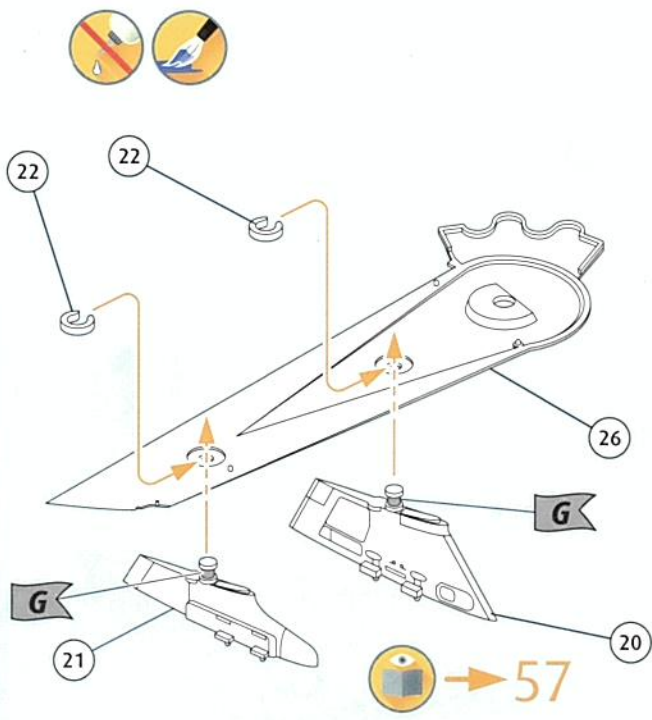

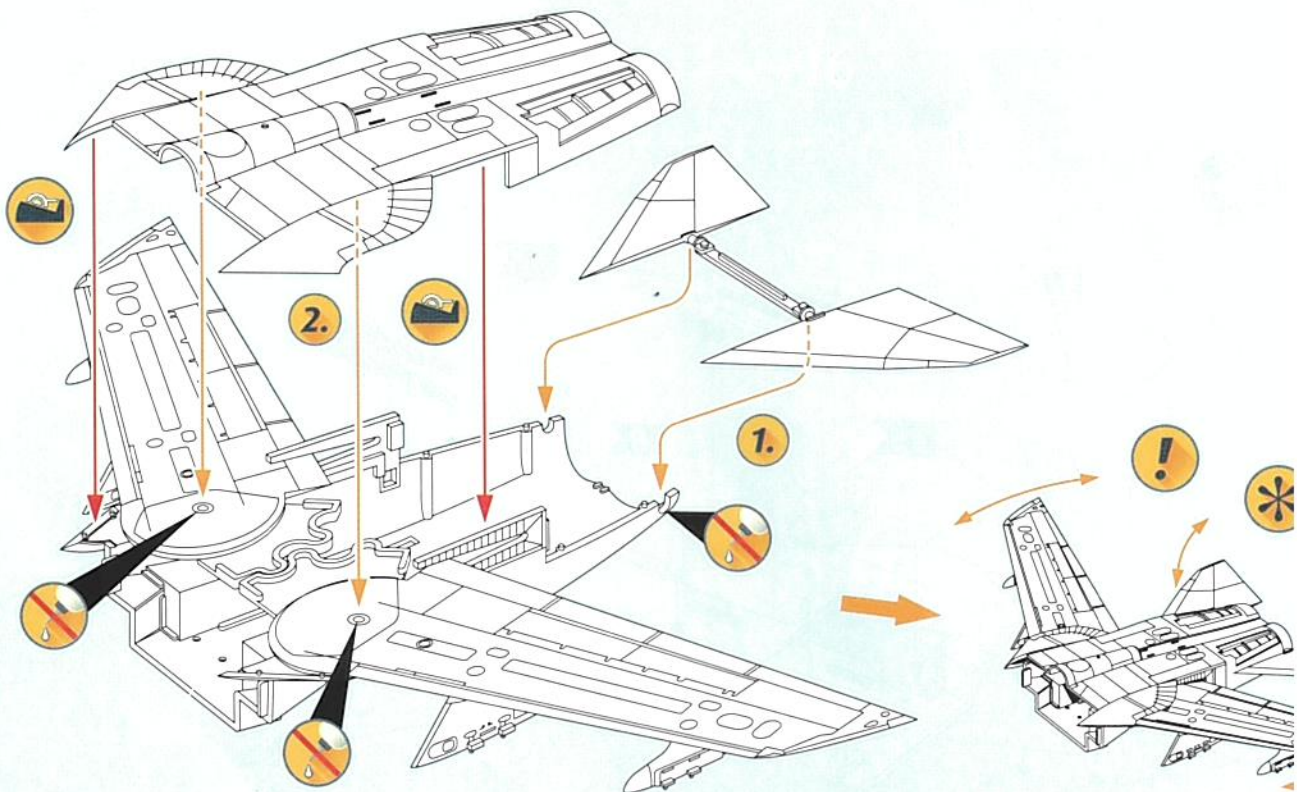
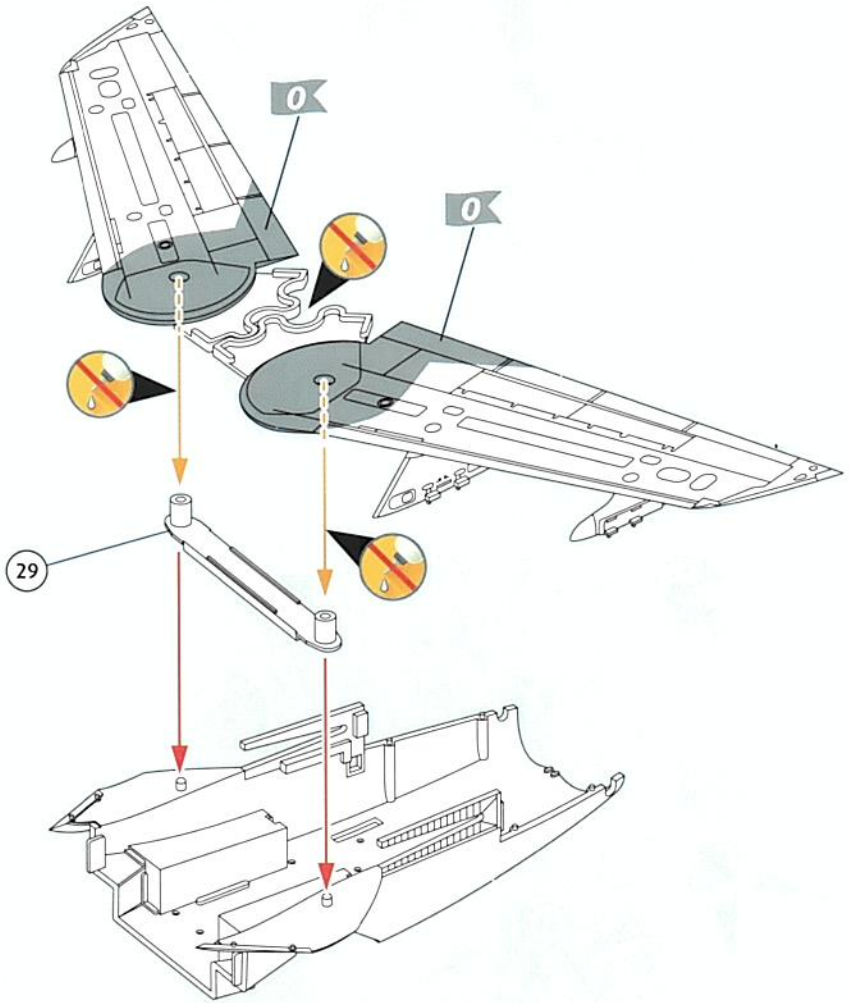

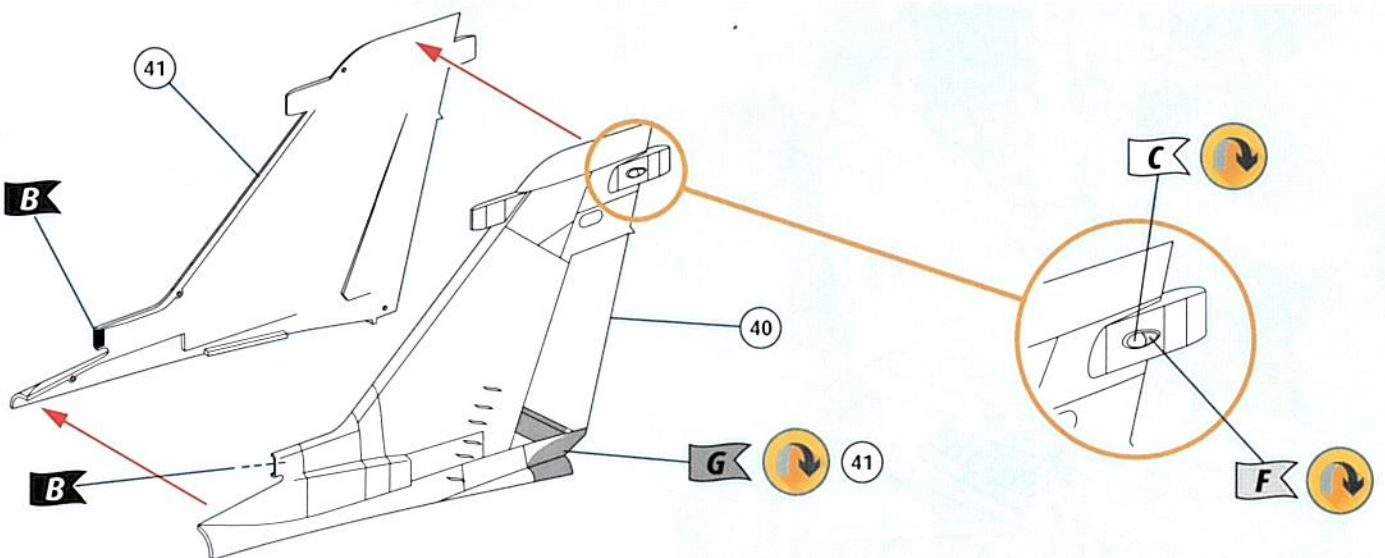
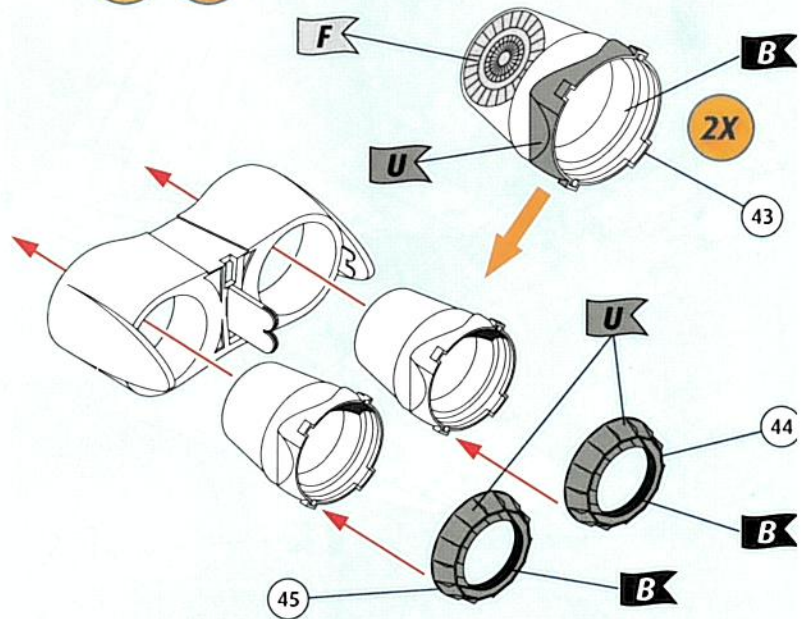
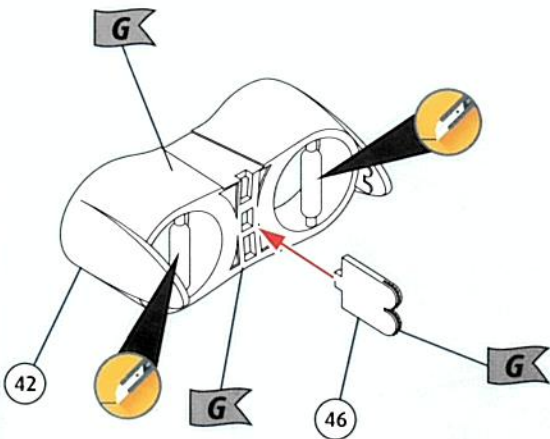
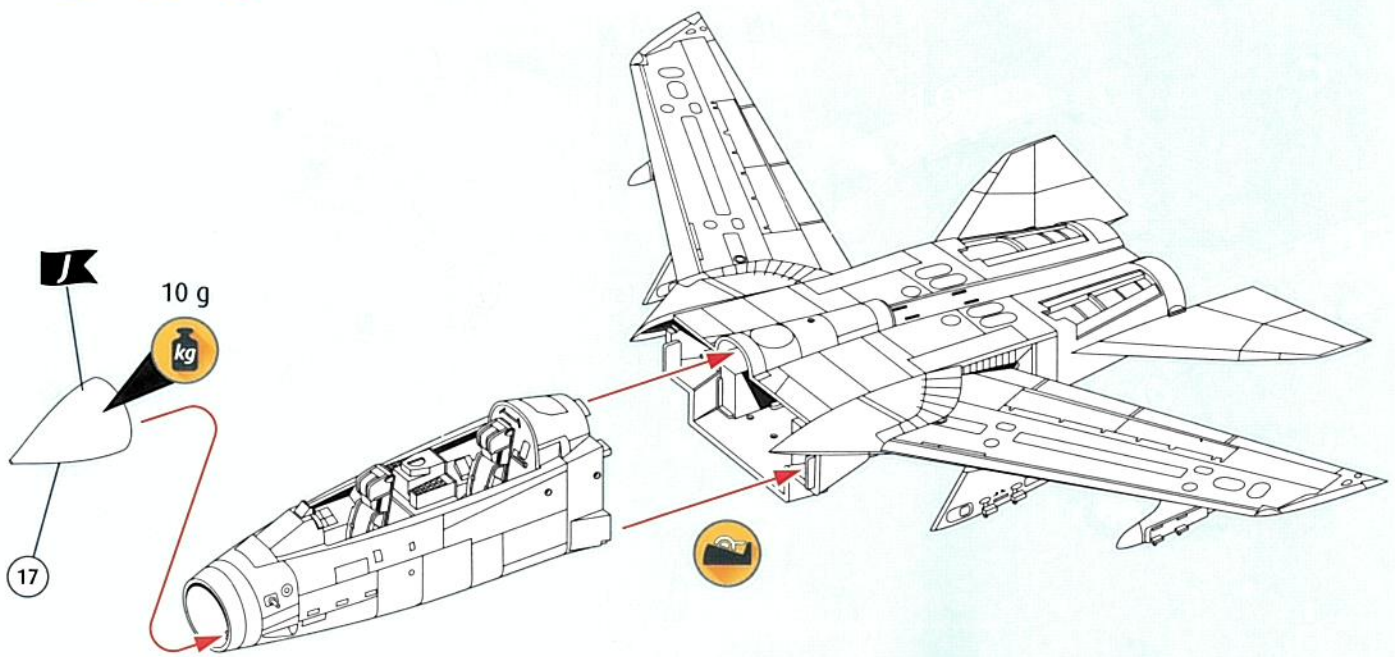

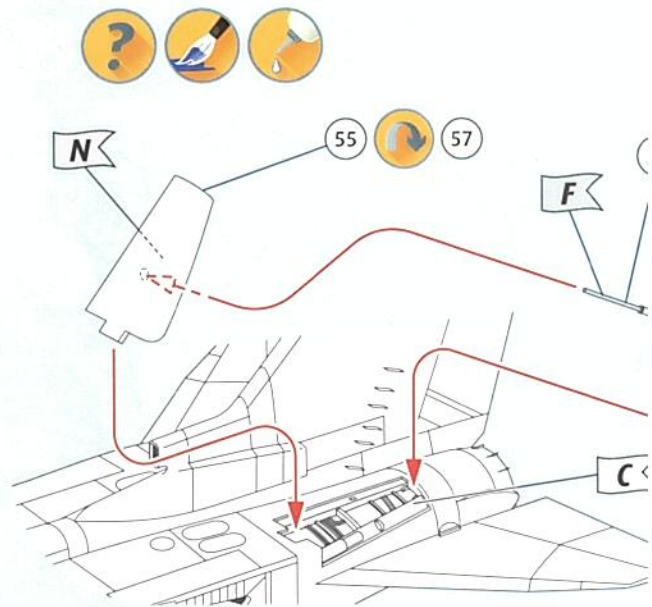
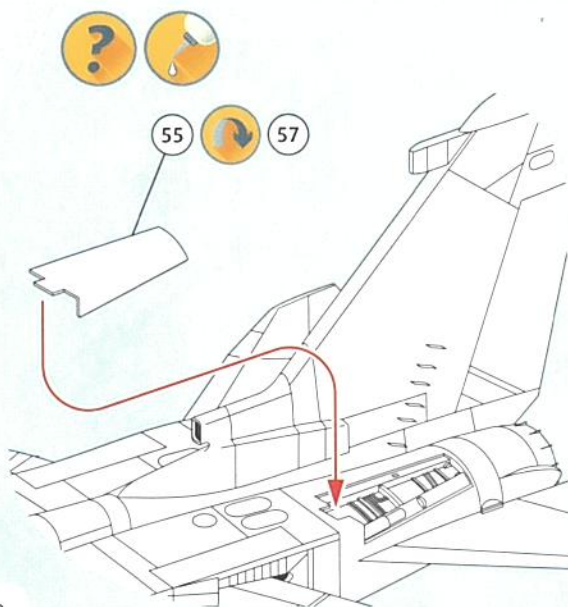
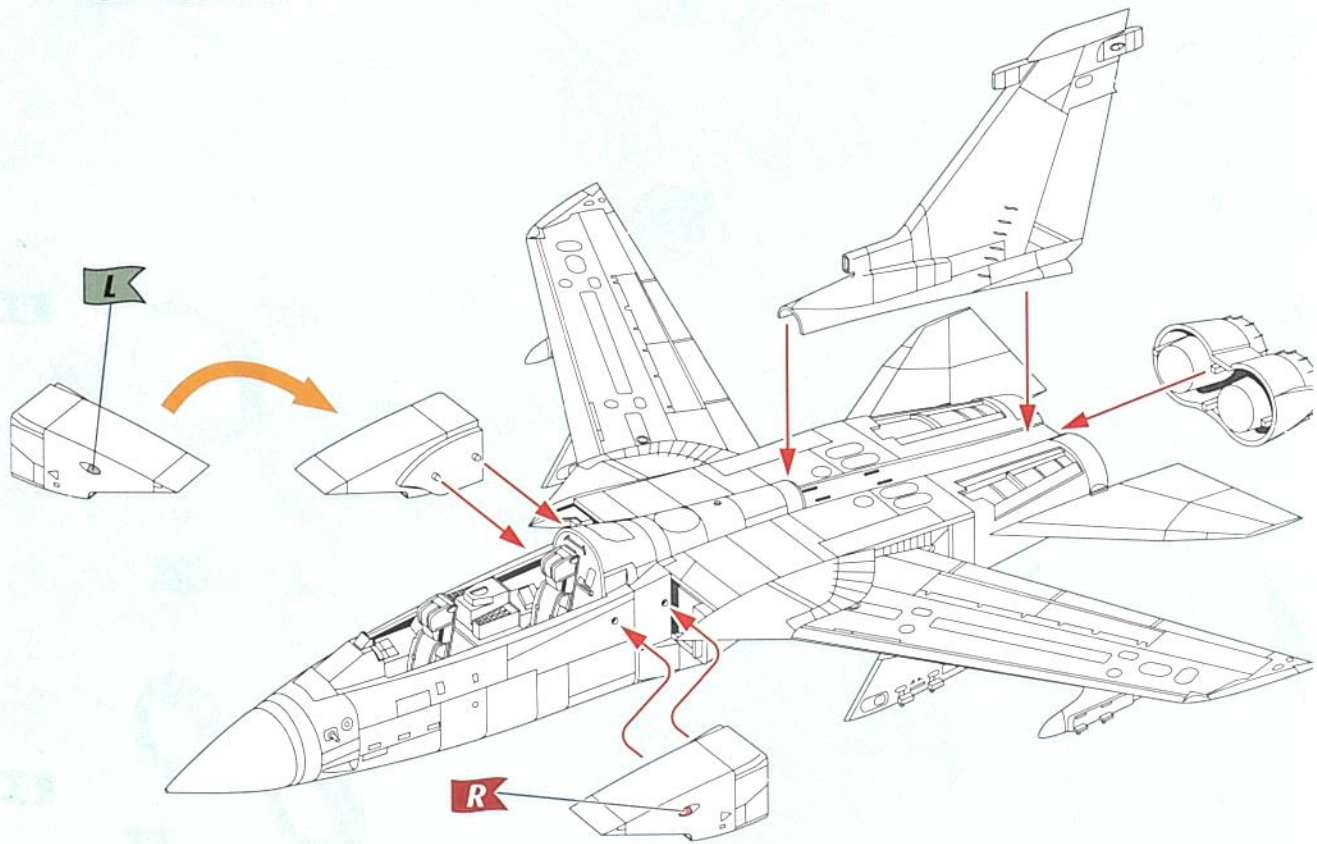
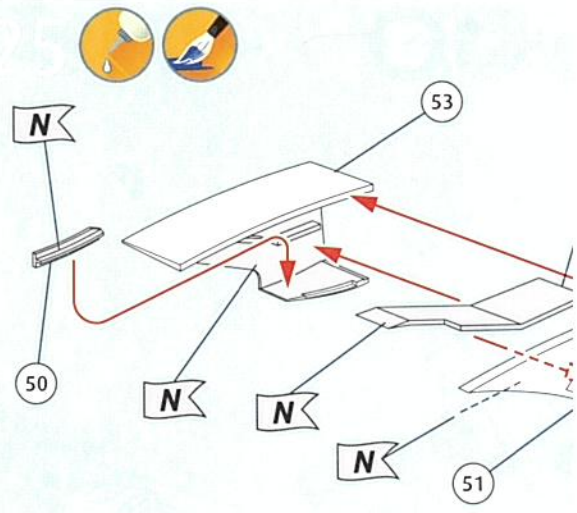
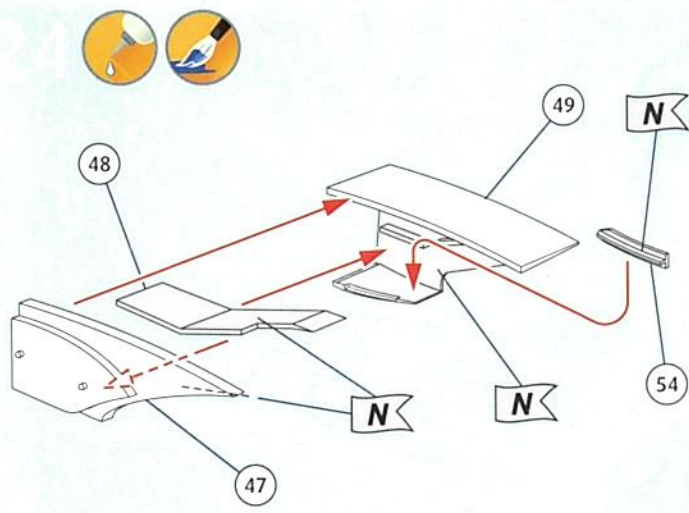

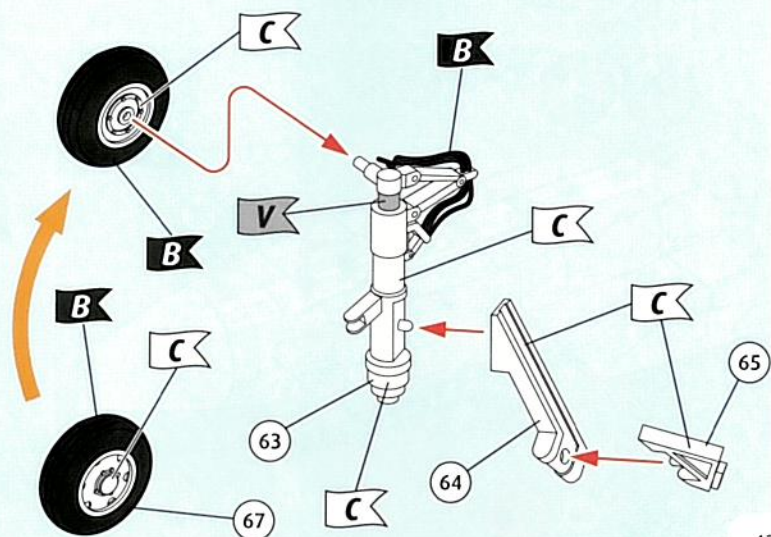
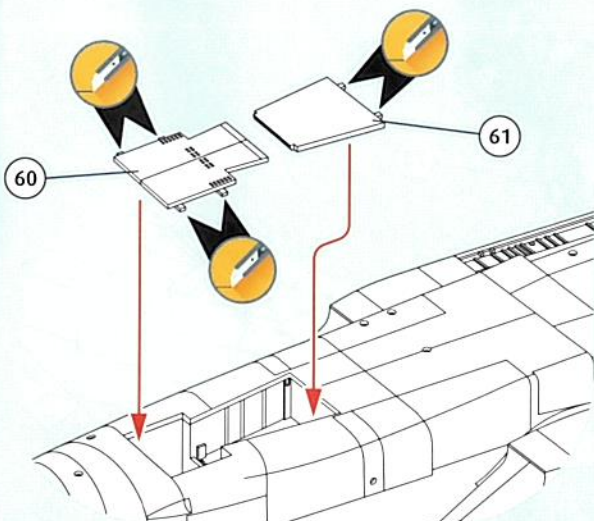
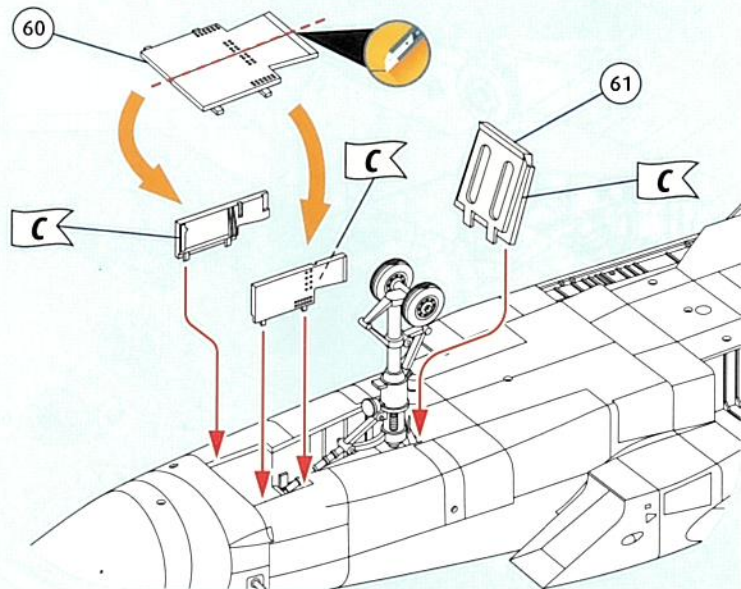
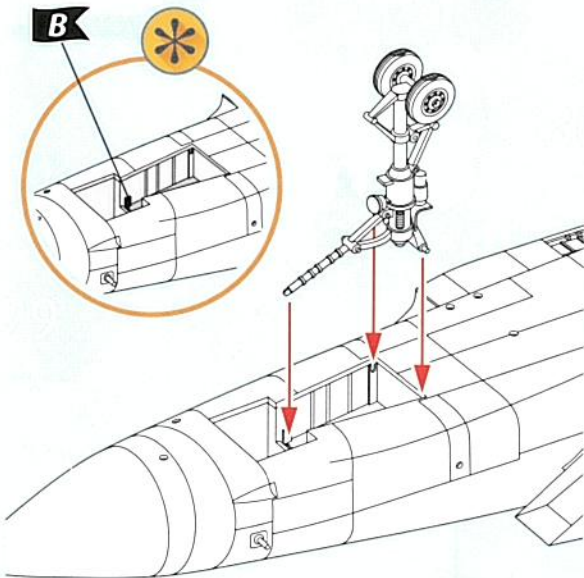
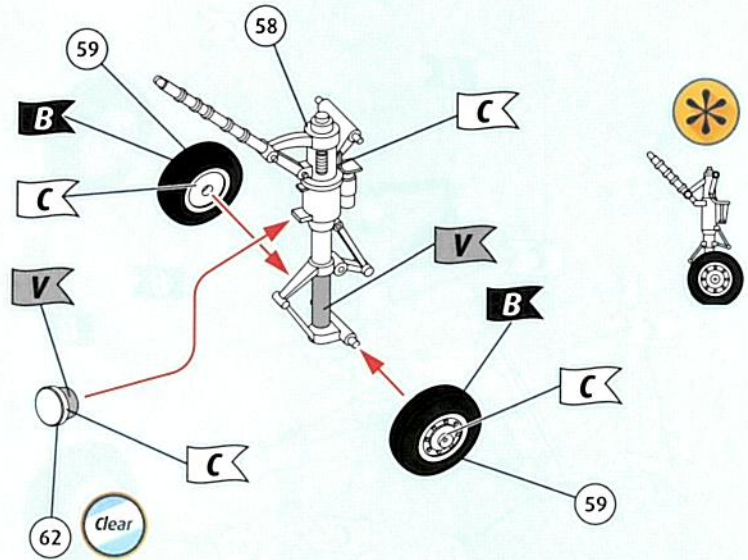
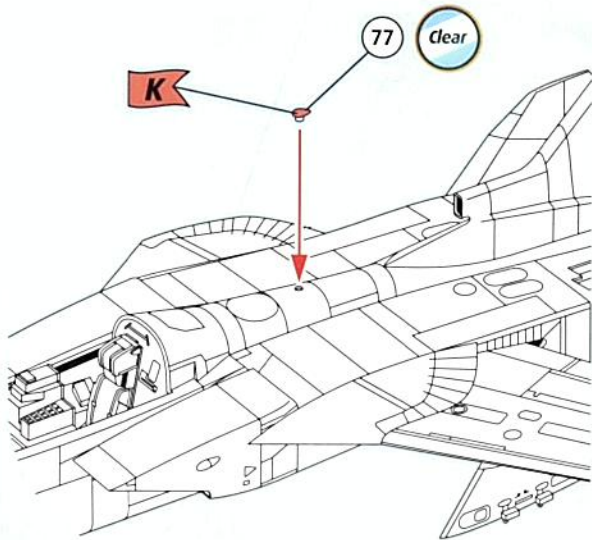

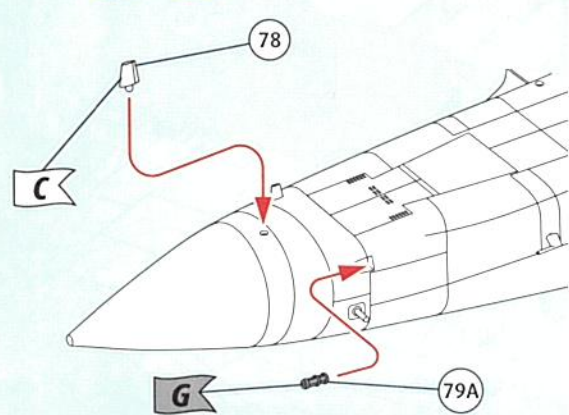
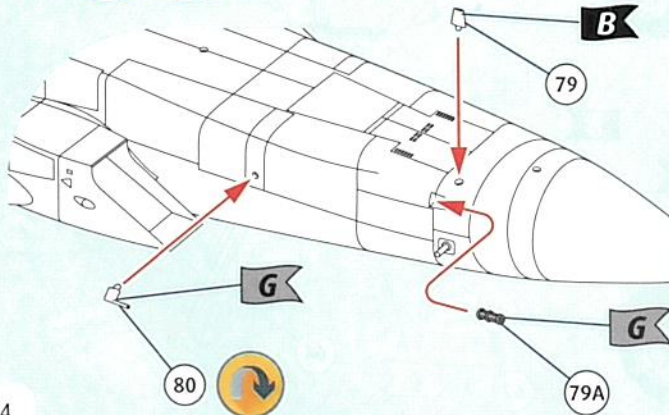
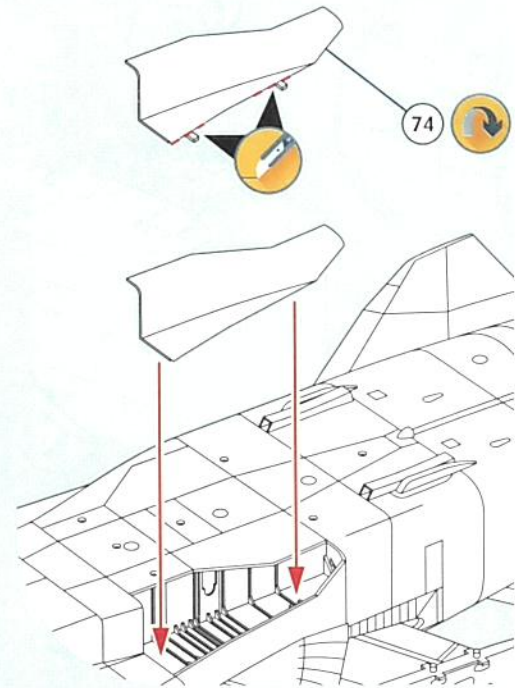
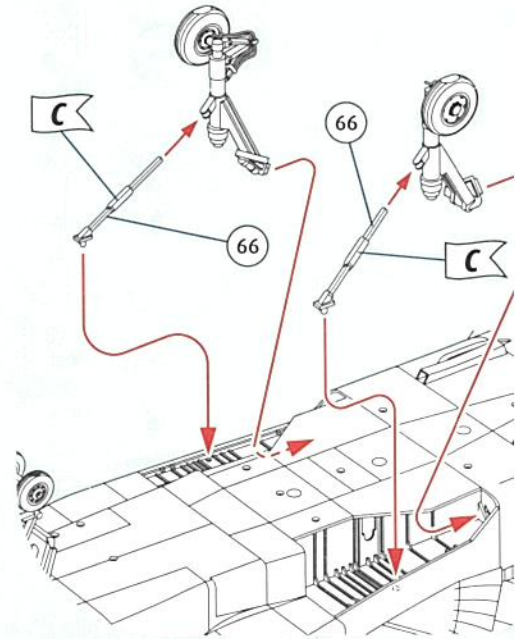
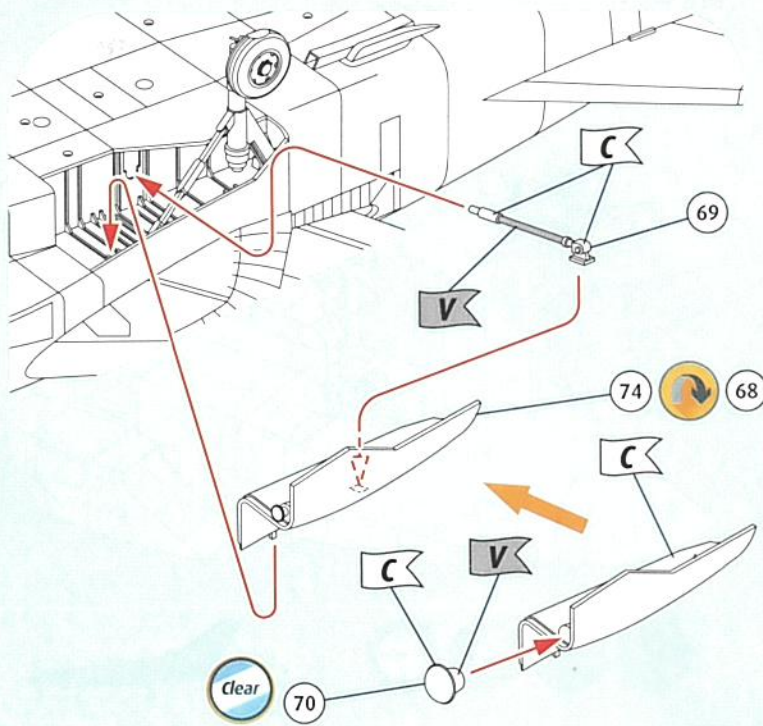
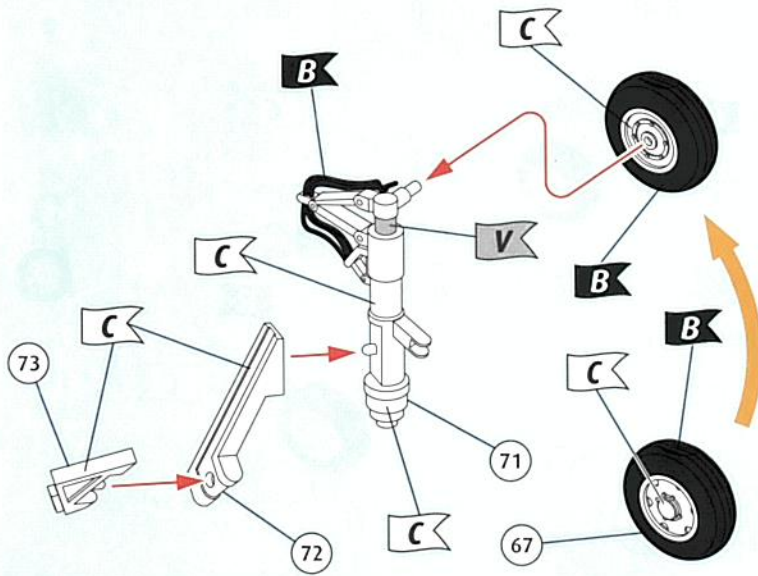

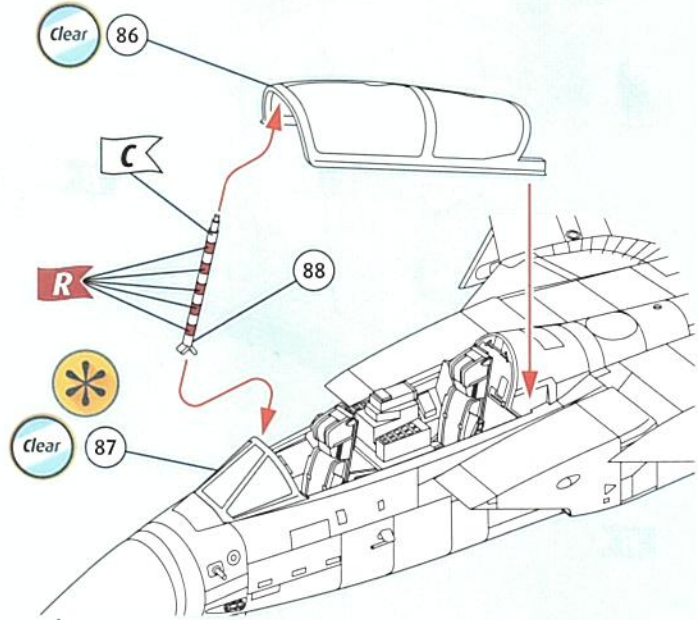
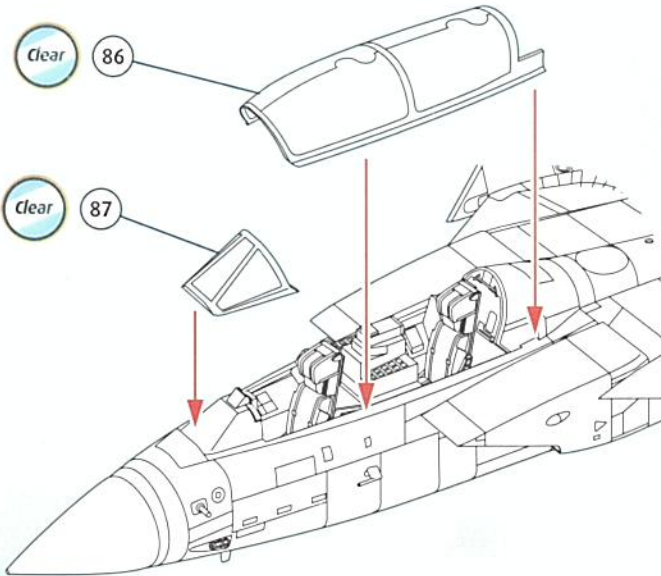
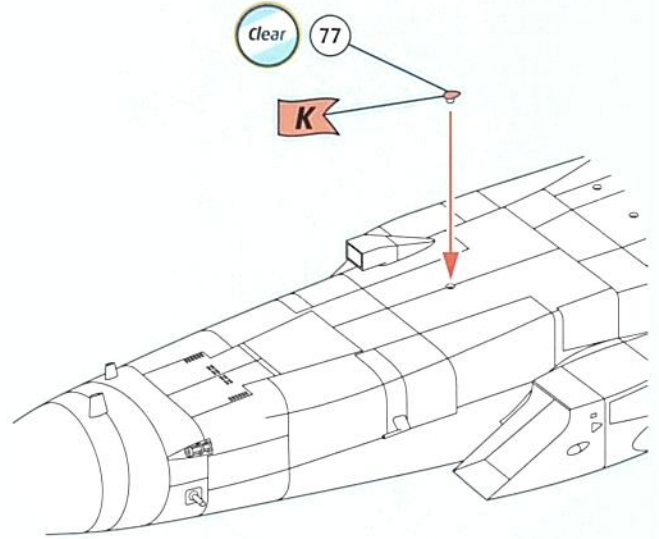
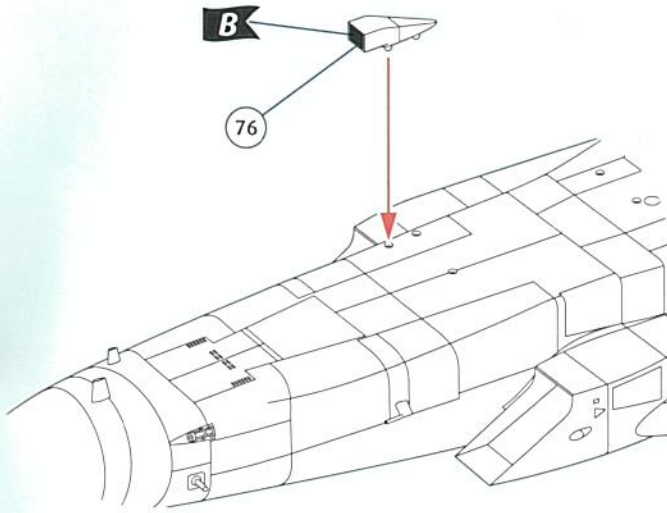

45

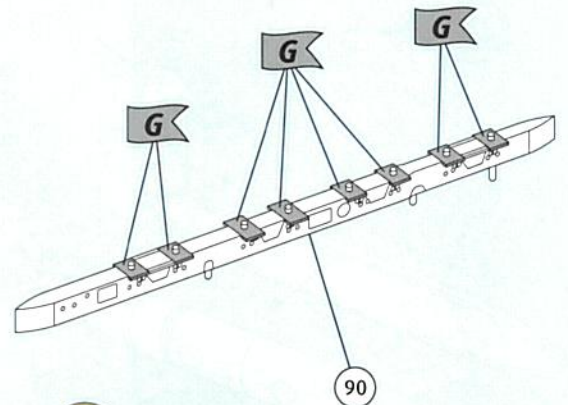
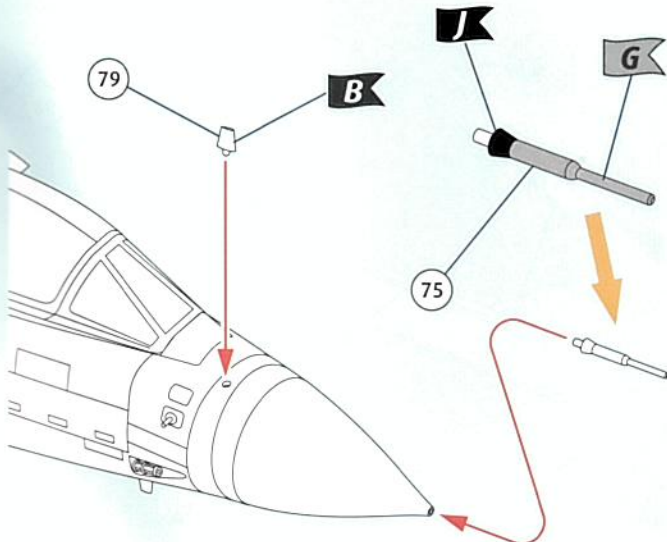

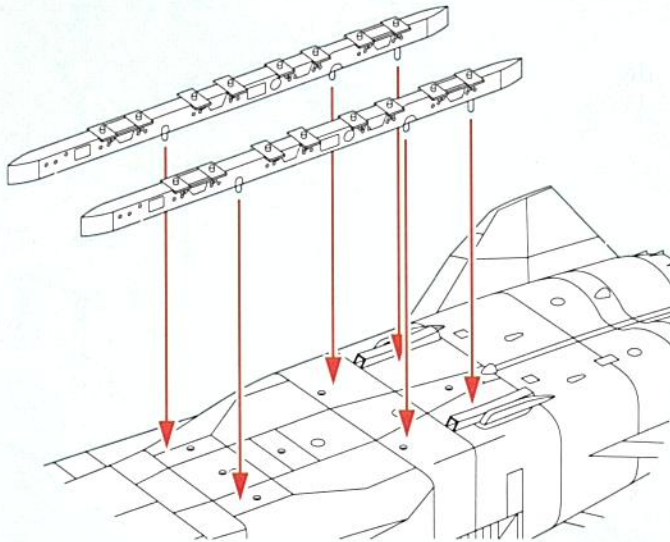

CERBERUS II ECM pod

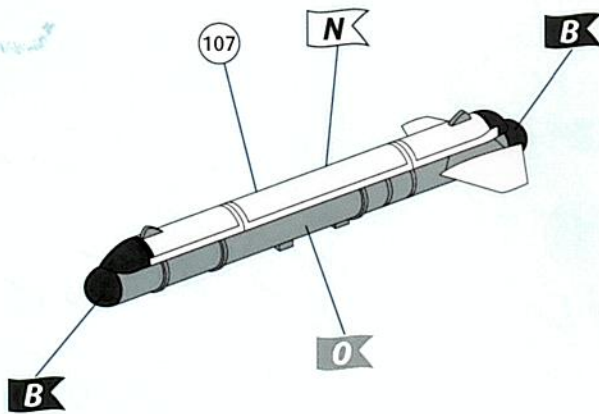

1500 Ltr. Fuel tank

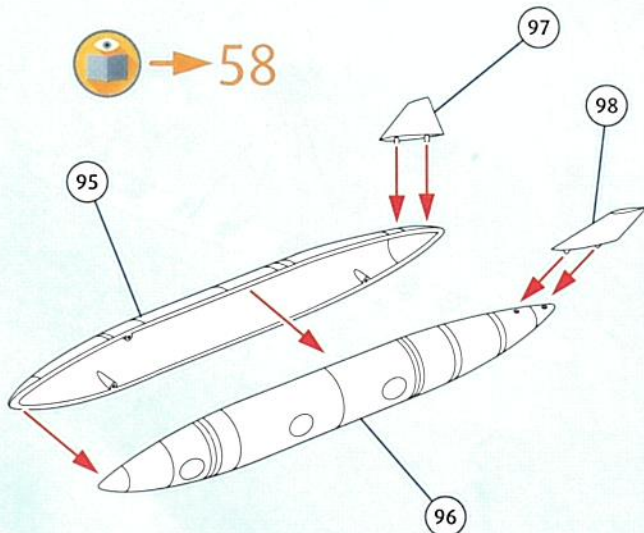

AIM-9L Sidew

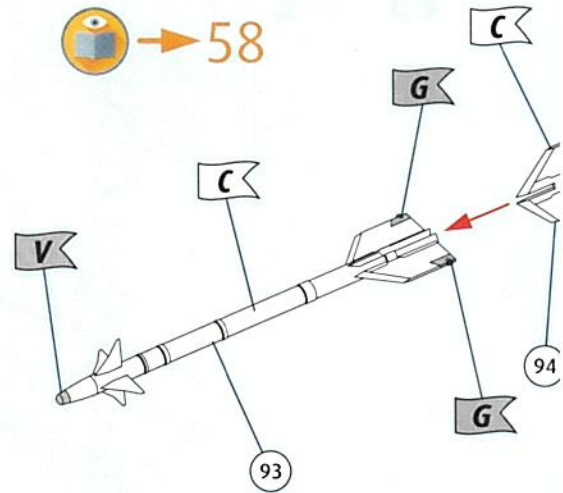

BOZ 101 counter-measu

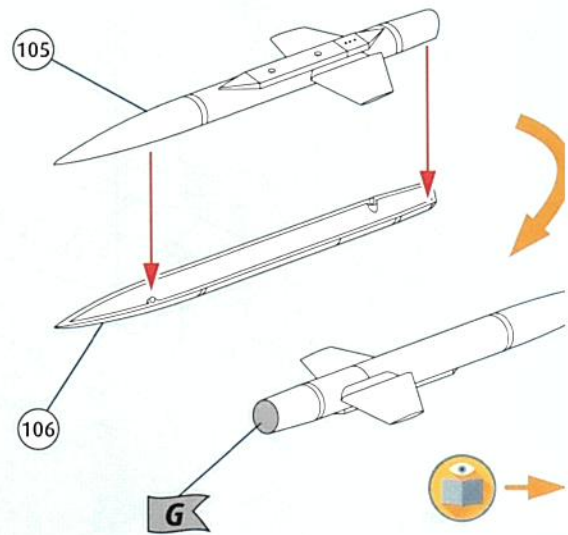

1500 Ltr. Fuel tank

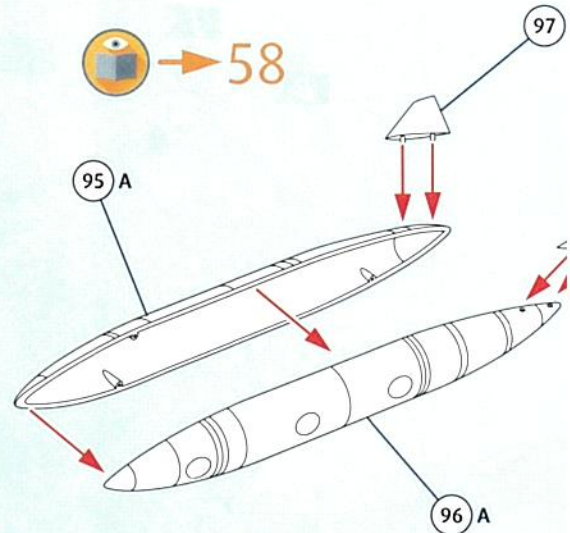

53

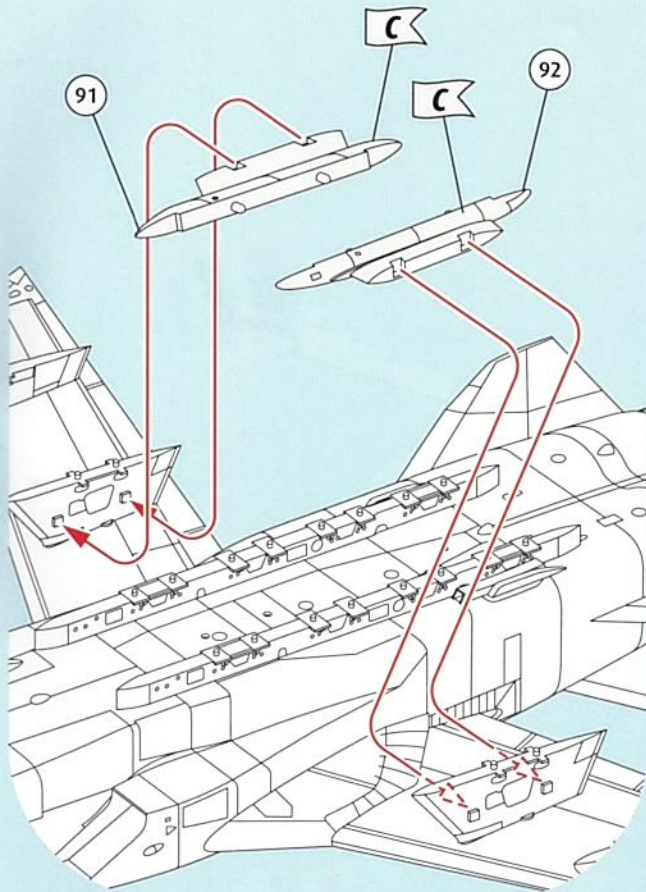

54

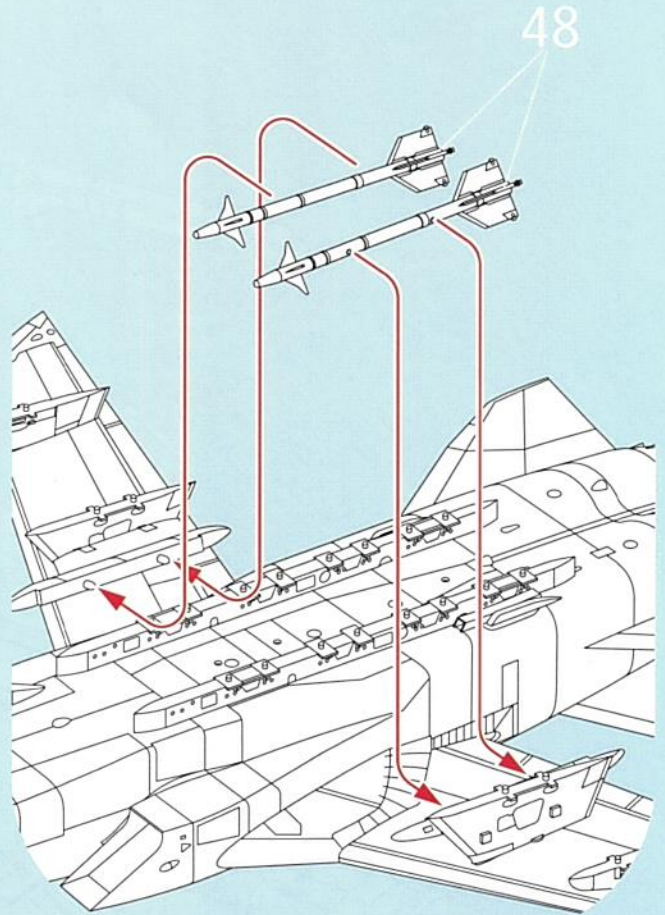

55

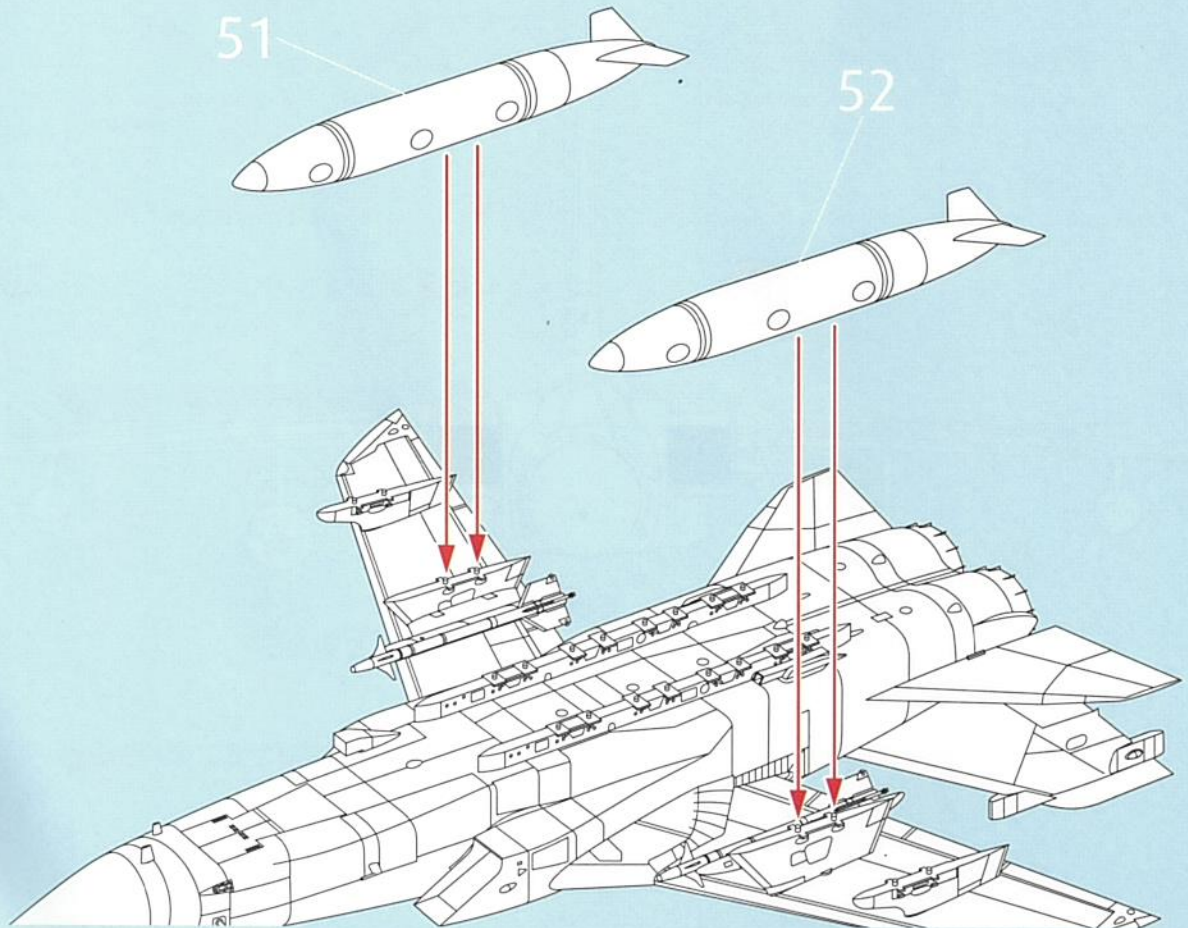

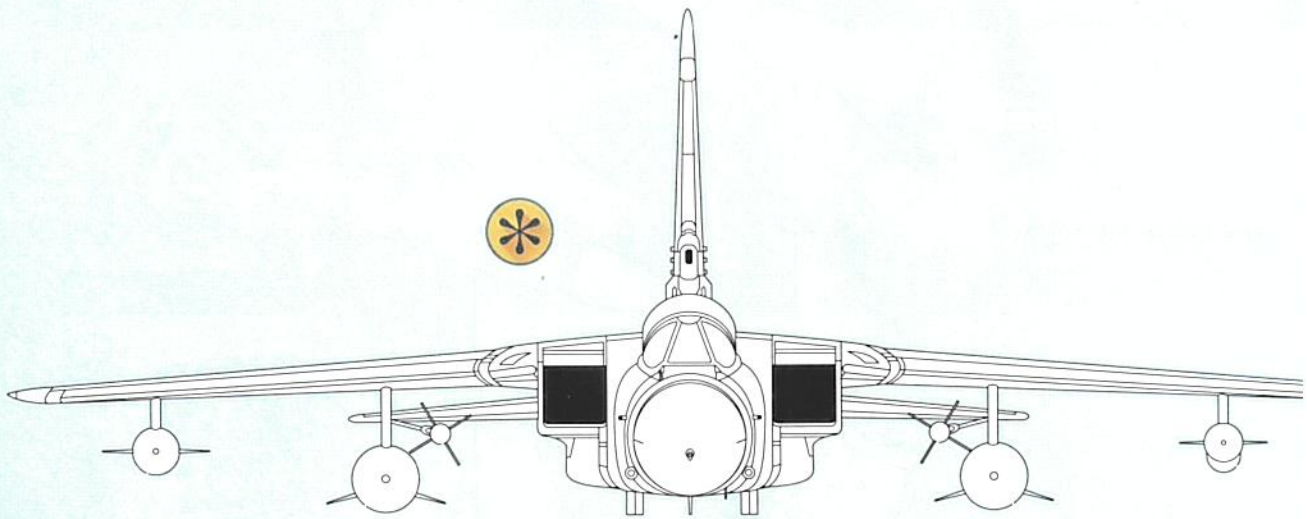
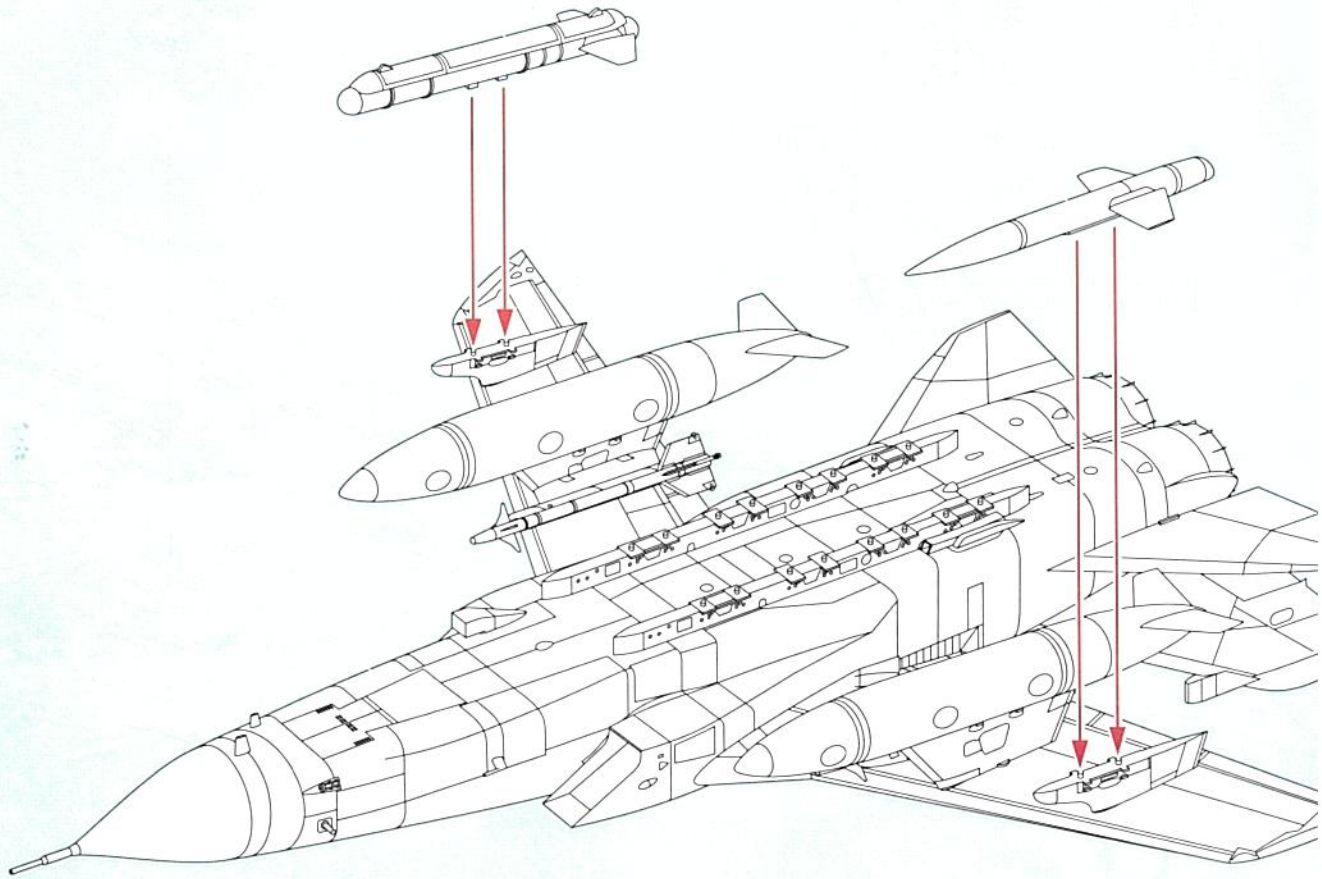



## Pylons, weapons & stores

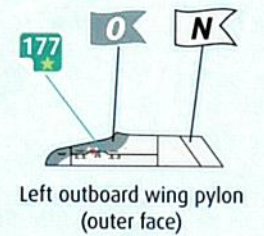
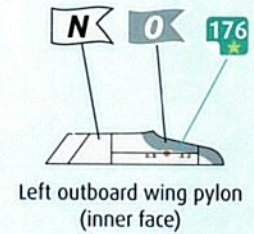
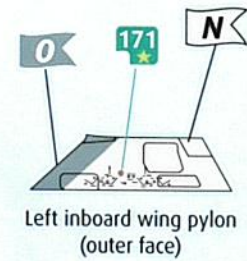
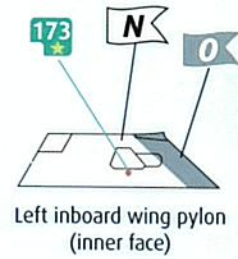
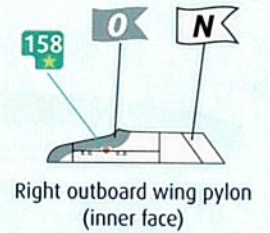
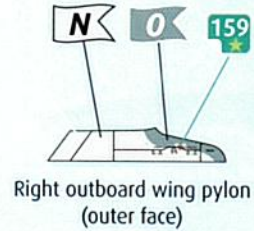
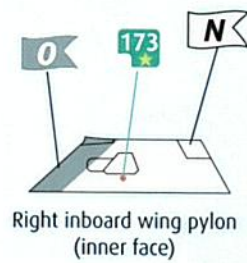
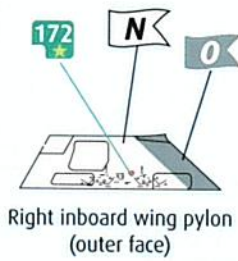
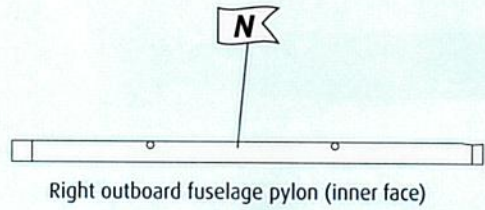
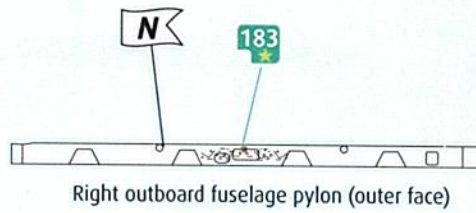
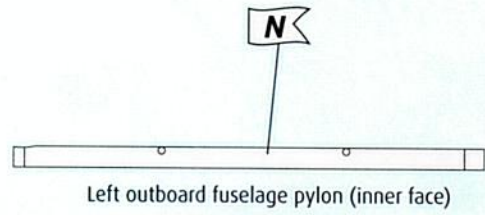
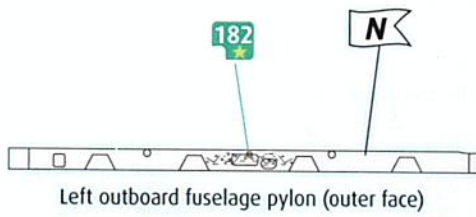

CERBERUS II ECM pod

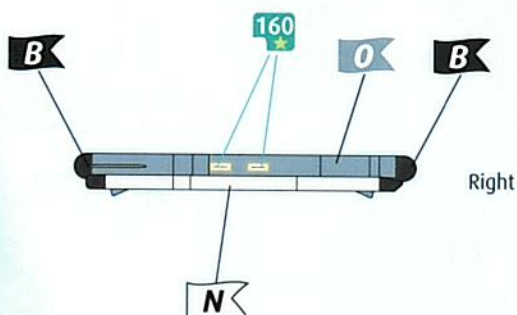
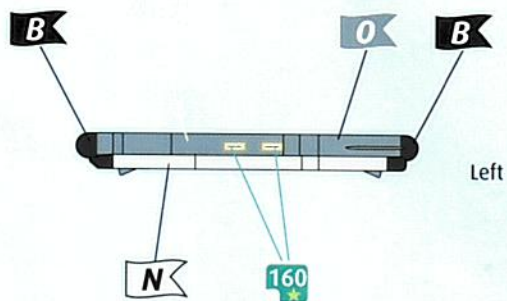

BOZ 101 ECM pod

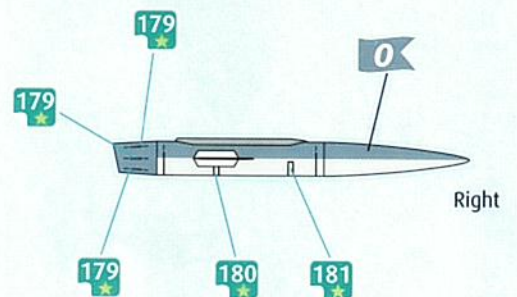
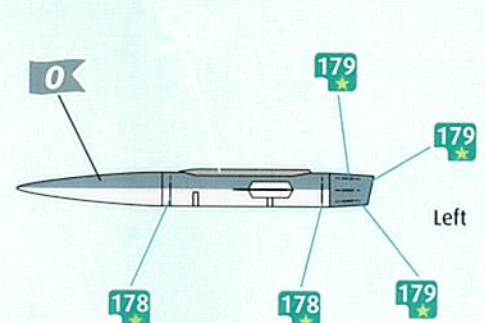



### pylons, weapons & stores

**2X** 1500 ltr fuel tank

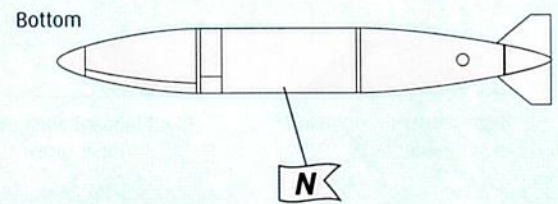
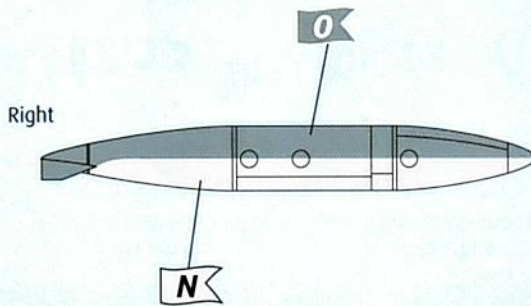
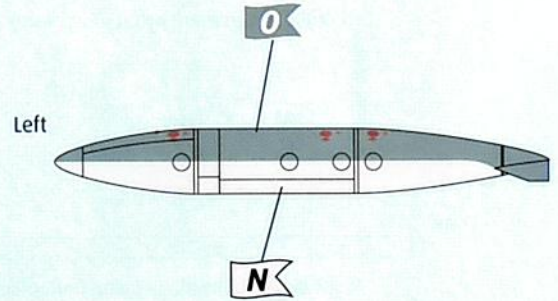
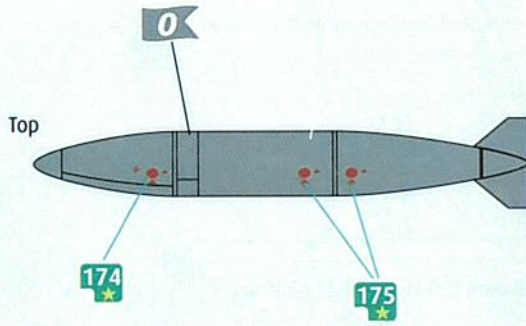

**2X** AIM-9L Sidewinder

